



INSTRUCTION MANUAL

 TM - Series

CLASSIC THERMO-ELECTRIC COOLERS

Model 8210

TABLE OF CONTENTS

A: Specifications.....	3
B: Limited Warranty.....	4
C: Principle of Operation.....	5
D: Installation	8
E: Start-up Procedure	9
F: LED Summary.....	10
G: Setpoints	11
H: Relay Board.....	12
I: “New Jersey” Thermocouple Option	13
J: Troubleshooting.....	14
K: Spare Parts.....	15
Appendix A: Classic Model 8210	18
Appendix B: Sample Conditioning System.....	19

A: SPECIFICATIONS

Physical Description

Single (Series) / Dual (Parallel) Channel System
2 x 10" Heat Exchangers connected in series or parallel
2 Active (cooled to 4°C) Heat Exchangers
LCD temperature display (dual)

Operating Specifications

Sample Gas Flow Range	3-10 LPM (Series configuration) 6.4-21.2 SCFH
Average Inlet Dew Point at Rated Flow	142°F @ 20% H ₂ O 61°C
Maximum Cooling Rate	248 BTU/Hr 261kJ/Hr
Dimensions	14.55 x 12.62 x 11.82 in. HWD 37.0 x 32.0 x 30.0 cm
Weight	35 lbs 16.0 kg
Maximum Inlet Sample Temperature	400°F (205°C) SS, Glass Impingers 280°F (138°C) Kynar Impinger
Maximum Inlet Pressure	45 psig 3 bar / 2250 mmHg
Maximum Heat Exchanger Pressure Drop	<+1 in. H ₂ O
Ambient Temperature Range	33-104°F 0.56-40°C
Outlet Sample Gas Dew Point	41°F 5°C
Inlet Tubing Connection	3/8 in. FPT
Outlet Tubing Connection	1/4 in. FPT
Drain Tubing Connection	3/8 in. FPT
Voltage	110 (220 optional) VAC 50/60 Hz
Thermoelectric Elements	40 mm
Power Supply	500W
Cooling Down Time	Less than 3 minutes

B: LIMITED WARRANTY

Perma Pure LLC WARRANTY and DISCLAIMERS

Perma Pure (Seller) warrants that product supplied hereunder shall, at the time of delivery to Buyer, conform to the published specifications of Seller and be free from defects in material and workmanship under normal use and service. Seller's sole obligation and liability under this warranty is limited to the repair or replacement at its factory, at Seller's option, of any such product which proves defective within one year after the date of original shipment from seller's factory (or for a normal usable lifetime if the product is a disposable or expendable item) and is found to be defective in material or workmanship by Seller's inspection.

Buyer agrees that (1) any technical advice, information, suggestions, or recommendations given to Buyer by Seller or any representative of Seller with respect to the product or the suitability or desirability of the product for an particular use or application are based solely on the general knowledge of Seller, are intended for information guidance only, and do not constitute any representation or warranty by Seller that the product shall in fact be suitable or desirable for any particular use or application; (2) Buyer takes sole responsibility for the use and applications to which the product is put and Buyer shall conduct all testing and analysis necessary to validate the use and application to which Buyer puts the product for which Buyer may recommend the use or application of the product by others; and (3) the characteristics, specifications, and/or properties of the product may be affected by the processing, treatment, handling, and/or manufacturing of the product by Buyer or others and Seller takes no responsibility for he nature or consequence of such operations or as to the suitability of the product for the purposes intended to be used by Buyer or others after being subjected to such operations.

SELLER MAKES NO OTHER WARRANTY, EXPRESS OR IMPLIED, OF THE PRODUCT SUPPLIED HEREUNDER, INCLUDING, WITHOUT LIMITATION, IMPLIED WARRANTIES OF MERCHANTABILITY AND FITNESS FOR PARTICULAR PURPOSE, AND ALL SUCH WARRANTIES ARE HEREBY EXPRESSLY EXCLUDED. SELLER SHALL HAVE NO LIABILITY FOR LOSS OF PROFITS, OR SPECIAL, INCIDENTAL, OR CONSEQUENTIAL DAMAGES UNDER ANY CIRCUMSTANCES OR LEGAL THEORY, WHETHER BASED ON NEGLIGENCE, BREACH OF WARRANTY, STRICT LIABILITY, TORT, CONTRACT, OR OTHERWISE. SELLER SHALL IN NO EVENT BE LIABLE IN RESPECT OF THIS ORDER AND OR PRODUCT DELIVERED ON ACCOUNT OF THIS ORDER FOR ANY AMOUNT GREATER THAN THAT PAID TO SELLER ON ACCOUNT OF THIS ORDER.

C: PRINCIPLE OF OPERATION

Thank you for purchasing the Perma Pure Baldwin™-Series Classic Model 8210 Thermo-Electric Cooler. Perma Pure's Classic Thermo-Electric Coolers are specifically designed for high ambient temperature & high water volume applications. Each model in our classic series feature an oversized heat sink and high performance thermoelectric devices for high heat removal capacity. Heat sinks used in Baldwin-series classic thermo-electric coolers are made out of high heat transfer extruded aluminum with large 3/4" thick end plates. Each model also incorporates a special controller specifically designed to run at high ambient temperatures.

The process of sampling combustion product stack gas or exhaust from internal combustion engines requires a method to remove the moisture from the sample, without removing the gas components of interest. The Baldwin Classic Thermo-Electric Cooler is an ideal way to decrease the dew point of combustion gases to a repeatable, stable, constant low dewpoint. The Baldwin-series cooler prevents water condensation in sample pre-filters, sample pumps, and gas analyzers. For gas analyzers where water vapor is an interferent, a stable, repeatable dewpoint becomes a part of the gas analyzer performance specification. Perma Pure coolers provide this constant low water concentration, resulting in an accurate component gas measurement.

All Baldwin-series coolers use thermo-electric elements (Peltiers) to cool the sample gas to the desired dew point temperature. A Classic Thermo-Electric Cooler is best illustrated as a small heat pump with no moving parts. The Peltiers operate on direct current and may be used for heating or cooling by reversing the direction of current flow. This is achieved by moving heat from one side of the module to the other with current flow and the laws of thermodynamics. A typical single stage Peltier (Figure 1) consists of two ceramic plates with p- and n-type semiconductor material

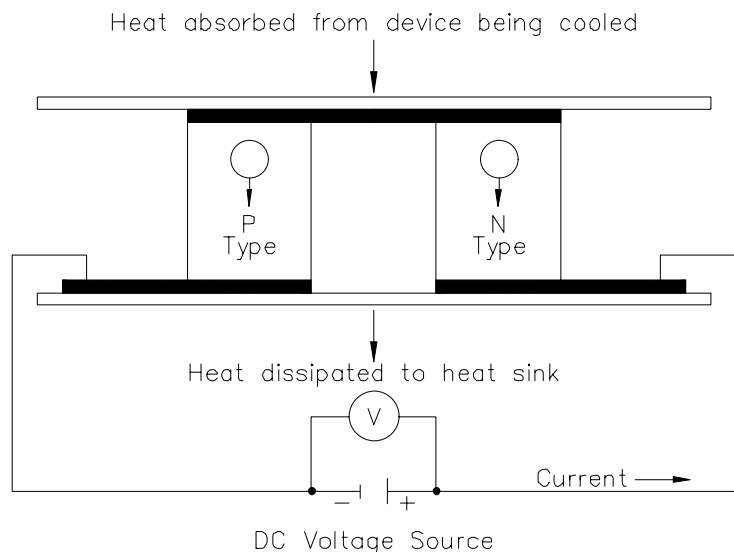

Figure 1: Thermo-electric element (Peltier)

(bismuth telluride) between the plates. The elements of semiconductor material are connected electrically in series and thermally in parallel.

When a positive DC voltage is applied to the n-type thermo-electric element, electrons pass from the p- to the n-type thermo-electric element and the cold side temperature will decrease as heat is absorbed. The heat absorption (cooling) is proportional to the current and the number of thermo-electric couples. This heat is transferred to the hot side of the Peltier element where it is dissipated into the heat sink and surrounding environment.

Baldwin™-series classic thermo-electric coolers remove the moisture from the sample gas by cooling the gas as it passes through a laminar impinger (heat exchanger). A diagram showing the gas flow path through an impinger is shown in the Appendix. The heat exchanger, made of 316L stainless steel, Durinert® (a corrosion-resistant inert coating over 316L stainless steel), PVDF (Kynar), or glass, is mounted within a thermally insulated heat transfer block bored to receive the heat exchanger without a mechanical lock. This assembly allows the easy removal of any heat exchanger simply by slipping it out of the cooling block by hand. The heat transfer block cools the heat exchanger through the heat pumping action of the peltier element. The heat transfer block is on the cold side of the thermo-electric element and the heat sink is on the hot side of the thermo-electric element. The heat from the heat transfer block is pumped to the heat sink where it is then dissipated into the air by the heat sink fan. See figure 2. The desired temperature is maintained by a closed loop control system, which is implemented through an analog proportional controller. The controller uses a type K thermocouple in the heat transfer block located very close to the cold side of the peltier element as the input sensor.

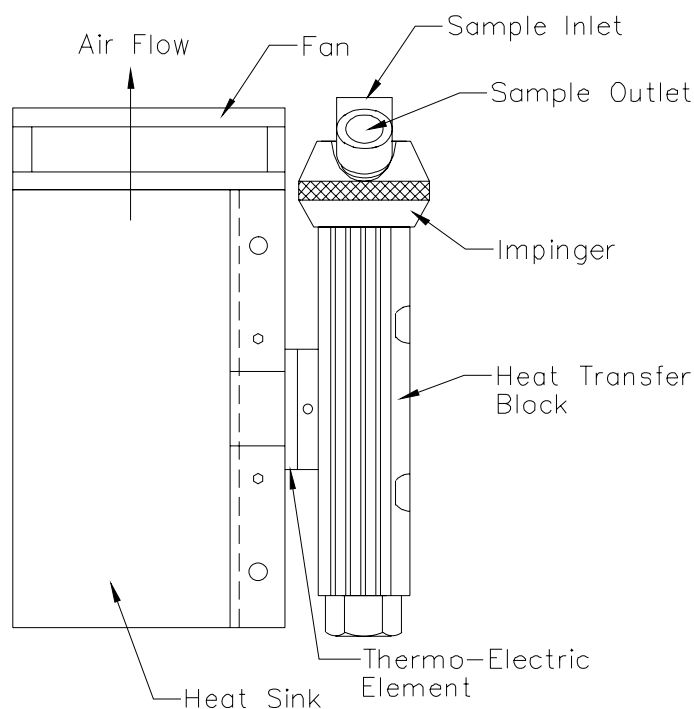

Figure 2: Heat Exchanger, Impinger and Heat Sink Assembly

The sample gas is passed to the Classic thermo-electric cooler via the heated filter sample probe and heated sample line. The Classic thermo-electric cooler lowers the sample dew point to 5°C (41°F). As the gas cools and the moisture vapor condenses, the condensate exits the heat exchanger through the bottom drain connection. Particulate matter which passes through the sample cooler is removed by an optional pre-filter, located downstream from the cooler along with an optional water slip sensor. The conditioned sample gas can then be directed to the gas analyzers.

D: INSTALLATION

The Classic Model 8210 Thermo-Electric Sample Cooler should be installed away from heat sources in a well ventilated area of an instrument rack or enclosure. *REMEMBER, the Classic Model 8210 can only control to 71° F. DIFFERENTIAL from ambient temperature.* Thus, at an output temperature control of 41° F., the maximum ambient temperature is 104° F., above which cooling control is lost. When this differential is exceeded, the controller will go full-on, with the cooling capacity floating in relation to the ambient temperature above 104° F. No damage will occur to the cooler, however, the output dew point will also float in relation to the ambient temperature. The more stable the ambient temperature environment around the Classic Model 8210, the better the output dew point stability.

Sample tubing connections to the Classic Model 8210 depend on the heat exchanger material of construction. A cooler with stainless steel heat exchangers uses a stainless steel inlet fitting on the Channel 1 heat exchanger. All other inlets and outlets are Kynar® standard compression type tube fittings with Teflon® ferrules. PVDF (Kynar®) heat exchangers use all Kynar® standard compression type tube fittings with Teflon® ferrules. Perma Pure cannot warrantee against damage to the Peltier elements or heat exchangers if our supplied Kynar® tube fittings are not used.

The inlet and outlet tubing of all metal or Kynar® heat exchangers is 1/4" NPT; the user should always use the compression type fittings provided for that purpose by the factory. The inlet of the Channel 1 heat exchanger uses a 3/8" tube x 1/4" MNPT, tube connector fitting to mate with most standard 3/8" sample lines.

The condensate drain connections are Kynar® elbows, 3/8" MNPT x 1/4" barbed tube fittings. An automatic condensate drain, Model 3KPB-003 dual-head peristaltic drain pump is recommended for water removal. This pump uses size 17 tubing.

CAUTION: Do no reduce the size of the condensate tubing since doing so restricts water flow resulting in water slip (moisture carryover) in the sample.

CAUTION: If using a stainless steel sample line, place 2 inches of Teflon® tubing in between the exchanger inlet fitting and the heated line. This prevents the sample cooler from heat sinking the incoming heated line, which adds undue load to the cooler.

E: START-UP PROCEDURE

Plug in the power cord to a properly grounded main circuit. The Ready Green LED will come on within 3 minutes, indicating the ready temperature (10°C) has been achieved and the gas sample flow can begin. After approximately 3 minutes, the set point of +5°C (41°F) will be achieved. The SLIP Green LED is always on unless, (1) moisture is detected by the water slip sensor, (2) the cooler was ordered without a relay board, or (3) there is a malfunction (e.g., shorted water slip sensor leads or a bad relay board).

The Baldwin™-series Classic model 8210 thermo-electric cooler is virtually maintenance free. However, in the event of electrical problems, refer to the troubleshooting guide in this manual. All voltages can be read at the PCB terminal strip. Any deviations from the correct voltages indicate a problem.

F: LED SUMMARY

The Classic Model 8210 has a dual-channel, digital operating temperature front panel indicator, and three LED status displays for each active channel (2 green, 1 red per channel). These indicators are arranged vertically on the front of the cooler on their respective sides. The toggle switch located to the right of the display and LED's allows selection of the temperature read-out for either channel 1 (right heat exchanger) or channel 2 (left heat exchanger). The "Ready" Green LED's come on when the relay set point temperature is reached for each channel. The "Slip" Green LED's light up immediately upon power-on, indicating that the water slip relay is not actuated, which is the expected normal condition. In a standard Classic Model 8210 where the heat exchangers are connected in series for a single gas stream, the channel 1 "Slip" LED is connected to the water slip sensor, which is normally dry on start up. If the "Slip" Green LED goes out, this indicates water is "slipping" past the heat exchanger. The relay then shuts off the sample pump so that water is not allowed to reach the analyzers, preventing damage to the analytical instruments. Steps need to be taken at this time to determine the cause of the moisture and correct the situation. The "Failure" red LED's come on if the thermocouple or an electronic controller component has failed.

READY LED On = Relay Set Point Temperature is Reached (+10°C)
SLIP LED On = Safe Operating Condition
SLIP LED Off = Water Slip Sensor Alarm (Unsafe Operating Condition)
Red LED On = Thermocouple or electronic Failure Alarm

When all Green LED's are lit, the Classic Model 8210 is operating at proper cooling block temperature, producing a stable, repeatable dewpoint, sample effluent. If either Green LED fails to light, it can indicate several problems. The first and most obvious is overload. Check the incoming sample gas temperature, moisture content, and flowrate through the heat exchangers to be sure all conditions are within published specifications. Overload requires more cooling power from the Classic Model 8210 than is available (max. is 250 Btu/Hr) (261 kJ/Hr). If all conditions are correct, then the problem is an electrical malfunction, which can be traced using the trouble shooting guidelines in Section I of this manual.

G: SET POINTS

Both the operating control temperature and ready relay set points are adjusted by 10 turn potentiometers located on the control board. Attach a digital multimeter (DVM) to Test Points 1, 2, 3, 4, 5, or 6; located just above terminal TB1 and TB2 where the control thermocouples terminate. TP1, 4 are the thermocouple zero/span adjustment test points, and should not be adjusted by the user. TP3, 6 are the ready relay set point temperatures (Set Point #3), and TP2, 5 are the control set point temperatures (Set Point #2). To adjust either set point, open the cooler front door, attach the DVM, and adjust the labeled potentiometer on the control card. There are two separate channel controllers and ready relay set points. Each impinger is controlled by its corresponding controller, right side of the control card is channel 2, left side of the control card, channel 1.

NOTE: These set point potentiometers are factory set and sealed for proper cooler operation. Please consult the factory before making any changes to these set point adjustments.

SET POINT #2 is factory adjusted to 5°C (.500VDC).

SET POINT #3 is factory adjusted to 10°C (1.00VDC).

H: RELAY BOARD

Note: For the following instructions, the terminal blocks specified in parentheses refer to the channel two section of the relay board. Both sections are identical except for the reference designators.

A: Computer Status Alarms

Wire computer status alarms to TB2 (TB6), Terminals 1 through 3 for the Water Slip Alarms status and TB2 (TB6), terminals 4 through 6 for the Ready/Slip alarm status.

B: Sample Pump Control-Water Slip Only

1. Jumper hot, neutral, and ground from the power supply line terminals to TB8 on the relay board.
2. Wire the sample pump power leads to TB2 (TB6), terminals 6 (Hot), 7 (Neutral), and 8 (Ground).

C: Sample Pump Control-Water Slip plus Ready/Slip/Power Fail Safe Start

1. Wire TB2 (TB6) and TB8 as in step B2 above.
2. Wire a jumper on TB1 (TB4) from terminal 3 to terminal 4, and wire another jumper on TB9 (TB10) from terminal 1 to terminal 2.
3. Wire sample pump hot wire to TB9 (TB10) terminal 5.
4. Wire Water Slip Sensor to TB2 (TB6) terminals 7 and 8.

Sample pump is now in series with Water Slip Sensor and the Ready/Slip/power failure relay, which will only allow the sample pump to start if both conditions are true, i.e. no water slip, and safe operating temperature of the sampling system.

I: “NEW JERSEY” THERMOCOUPLE OPTION

Some air quality management districts (e.g., those in New Jersey and Southern California) require temperature measurement of the gas stream at the outlet of the last heat exchanger on the cooler. Perma Pure offers a 1/32-inch diameter hypodermic-style type K thermocouple that can be inserted into a special heat exchanger (i.e., it has a small port for insertion of the thermocouple) so the actual sample dew point temperature can be measured. This is sometimes referred to as the New Jersey thermocouple outlet temperature option.

The Classic Model 8210 has two 10” heat exchangers which can be operated in series (single-stream) or in parallel (dual-streams). When run in series, the second heat exchanger will have a New Jersey thermocouple to sense the temperature inside the heat exchanger (upgrade option: 4C-NJ/K-10). A quantity of two (2) 4C-NJ/K-10 are required for each cooler when used for dual-streams. In the part number, the “NJ” identifies the upgrade for a NJ type thermocouple. The “K” identifies the thermocouple itself as a type “K” thermocouple. The “-10” is the height of the heat exchangers.

In addition, Perma Pure offers an optional temperature transmitter board for signal or voltage temperature output. This board has one input and two outputs per channel. The input is for the type K thermocouple. The first output is an analog voltage output that can be configured for either 0-2.5vdc or 0-10vdc for a 0°C (32°F) to 25°C (77°F) temperature range. The second output is a 4-20mA for the same temperature range.

A single-channel NJ thermocouple transmitter board (3CCB-012) is used when the Classic Model 8210 is operated in series (single stream). A dual-channel NJ thermocouple transmitter board (3CCB-013) - one channel per gas stream - is used when the Classic Model 8210 is run in parallel (dual stream).

Classic Model 8210 New Jersey Thermocouple Option

Part No.	Description
4C-NJ/K-10	Heat exchanger upgrade to include NJ thermocouple port
3CXS-004	Heat exchanger, 10” SS w/ NJ thermocouple port
3CXD-004	Heat exchanger, 10” Durinert [®] w/ NJ thermocouple port
3CXK-004	Heat exchanger, 10” Kynar [®] w/ NJ thermocouple port
3CCB-012	Temperature transmitter board, single stream
3CCB-013	Temperature transmitter board, dual-stream
3KTC-001	Thermocouple, Type K, replacement kit

J: TROUBLESHOOTING

<i>Symptom</i>	<i>Check</i>	<i>Action</i>
No LED(s) and no fan.	AC power input. DC 3A fuse (F1) on control Bd. AC 15A fuse on power supply. Check for +15VDC at P1 & P11 of control bd.	Ensure that AC power is connected. Replace fuse as necessary. Replace fuse as necessary. If low reading, remove wires from P1 & P11, measure at power supply and replace supply if voltage still is low.
LED(s) on and no fan.	Wire harness at P10 on control board over to P1 on relay boards. Relay Board for +12VDC at TB7 pins 1&2 and 3&4.	If loose then reseal connectors. If no voltage or low reading, replace relay board.
F1 on control board keeps blowing.	Replace fuse (3A) and disconnect P10 cable going to relay board.	If fuse does not blow, replace relay board.
Impinger remains at ambient temperature.	Peltier current draw. Should be above 6 amps.	Replace Peltier element.
Thermocouple failure LED is on.	Thermocouple connection TB1, 3.	Ensure proper connection. Try a good thermocouple in place of old one Replace thermocouple.
Impinger frozen and cooler indicates ambient temperature.	Thermocouple placement in heat exchanger block. Peltier current draw (>6A) for both elements on that channel.	Ensure proper placement. Replace bad peltier
Impinger does not reach set temperature, but is below ready temperature.	System loading. Calibration and set temperature adjustment.	Ensure system loading is not exceeding cooler capacity. Adjust as necessary.
Impinger temperature cycles up and down.	Peltier connections on control board. Ferrite beads on thermocouples going into terminal TB1 & TB2	Ensure a firm connection on flag connectors on control board. Ensure system loading is not exceeding cooler capacity. Wrap a Ferrite bead around thermocouple wires
Ready LED does not come on when impinger is below 7°C.	Ready temperature adjustment.	Adjust as necessary.
Water carryover in system.	Impinger temperature. Should be below 6°C.	Ensure system loading is not exceeding cooler capacity.
Slip LED does not come on (<i>alarm relay/water slip option installed</i>).	Water carryover in system. Water slip sensor connections.	Ensure system loading is not exceeding cooler capacity. Ensure that all water slip sensor connections are made. Disconnect sensor at base of unit, Clean tip of sensor. Replace alarm relay/water slip board.
Pump does not start. Ready and slip LED(s) are on (<i>alarm relay/water slip option installed</i>).	Pump electrical connections.	Ensure proper connections. Replace board.

For further service assistance, contact:

Perma Pure

P.O. Box 2105

8 Executive Drive (08755)

Toms River, NJ 08754

Tel: 800-337-3762 (toll free U.S.)

Tel: 732-244-0010

Fax: 732-244-8140

Email: info@permapure.com

or your local representative

K: SPARE PARTS

Classic Model 8210

Part No.	Description
3CCB-011*	Control Board: Dual Channel
2FAN-005	Fan: Muffin, 4" x 1", 12 VDC
2FAN-007	Fan: Muffin, 6" x 1½", 12 VDC
3CXD-003	Heat Exchanger: 10" Durinert®
3CXG-006	Heat Exchanger: 10" Glass, threaded w/ fittings
3CXK-003	Heat Exchanger: 10" Kynar
3CXS-003	Heat Exchanger: 10" Stainless Steel
3KPE-004*	Peltier Element Kit, 40 mm
1PSD-009*	Power Supply: 500W, 15VDC
3CCB-005*	Relay Board: Dual Channel
1TTC-001	Thermocouple: Temperature, Control, Type K, 24"

* Recommended Spares

Sample Conditioning Systems w/ Classic Model 8210 Thermo-Electric Cooler

Model C1 (Models 4S-8210-9BC1, 4S-8210-9EC1)

Part No.	Description
3KFA-001	Filter Assembly, Sample in-line, 2-micron
3FHG-001	Filter Bowl, Glass
3FEC-002**	Filter Element: Ceramic, 2-micron
3KPB-003	Peristaltic Pump: Dual, Kit, 115V Complete w/ Enclosure
2PBM-003	Peristaltic Pump: Head Only, Standard
2PBM-001	Peristaltic Pump: Motor Only, 115V AC 60 Hz
2PBT-002PK*	Peristaltic Pump: Tubing, Norprene, Size 17 (10 feet)
3KPA-001*	Sample Pump: Assembly, Single Head w/ Check Valve, 115V
2PAS-008	Sample Pump: Single Head, Mini-Dia-Vac, 115V (bare)
2PAM-001*	Sample Pump: Repair Kit, Single
3CWS-001	Water Slip Sensor (Hastelloy/SS Pins)
3KCW-002	Water Slip Sensor (SS Pins) w/ Holder Assembly

* Recommended Spares **Consumables

Model CD (Models 4S-8210-9BCD, 4S-8210-9ECD)

Part No.	Description
3KFA-001	Filter Assembly, Sample in-line, 2-micron
3FHG-001	Filter Bowl, Glass
3FEC-002*	Filter Element: Ceramic, 2-micron
3KPB-003	Peristaltic Pump: Dual, Kit, 115V Complete w/ Enclosure
2PBM-003	Peristaltic Pump: Head Only, Standard
2PBM-001	Peristaltic Pump: Motor Only, 115V AC 60 Hz
2PBT-002PK*	Peristaltic Pump: Tubing, Norprene, Size 17 (10 feet)
3KPA-002*	Sample Pump: Assembly, Dual Head w/ Check Valve, 115V
2PAD-006	Sample Pump: Dual Head, Mini-Dia-Vac, 115V (bare)
2PAM-002*	Sample Pump: Repair Kit, Dual
3CWS-001	Water Slip Sensor (Hastelloy/SS Pins)
3KCW-002	Water Slip Sensor (SS Pins) w/ Holder Assembly

* Recommended Spares **Consumables

Model CD2 (Models 4S-8210-9BCD2, 4S-8210-9ECD2)

Part No.	Description
3KFA-001	Filter Assembly, Sample in-line, 2-micron
3FHG-001	Filter Bowl, Glass
3FEC-002**	Filter Element: Ceramic, 2-micron
3KPB-003	Peristaltic Pump: Dual, Kit, 115V Complete w/ Enclosure
2PBM-003	Peristaltic Pump: Head Only, Standard
2PBM-001	Peristaltic Pump: Motor Only, 115V AC 60 Hz
2PBT-002PK	Peristaltic Pump: Tubing, Norprene, Size 17 (10 feet)
3KPA-002*	Sample Pump: Assembly, Dual Head w/ Check Valve, 115V
2PAD-006	Sample Pump: Dual Head, Mini-Dia-Vac, 115V (bare)
2PAM-002*	Sample Pump: Repair Kit, Dual
3CWS-001	Water Slip Sensor (Hastelloy/SS Pins)
3KCW-002	Water Slip Sensor (SS Pins) w/ Holder Assembly
3CWS-001	Water Slip Sensor (Hastelloy/SS Pins)
3KCW-002	Water Slip Sensor (SS Pins) w/ Holder Assembly

* Recommended Spares **Consumables

APPENDIX A: CLASSIC MODEL 8210

THERMO-ELECTRIC COOLERS

Classic Model 8210

Perma Pure's Baldwin™ Classic Series Model 8210 Thermo-Electric Coolers is specifically designed for high ambient temperature & high water volume applications and can be used in single stream or dual stream applications. The Model 8210 features an oversized heat sink and high performance thermoelectric devices for high heat removal capacity. Heat sinks used in the Baldwin-Series Thermo-Electric Coolers are made out of high heat transfer extruded aluminum with large 3/4" thick end plates. The Model 8210 incorporates a special controller specifically designed to run at high ambient temperatures up to 110°F (43°C).

Physical Description

Single (Series) / Dual (Parallel) Channel System
 2 x 10" Heat Exchangers connected in series or parallel
 2 Active (cooled to 4°C) Heat Exchangers
 LCD temperature display

Operating Specifications

Sample Gas Flow Range	3-10 LPM (Series configuration) 6.4-21.2 SCFH
Average Inlet Dew Point at Rated Flow	142°F @ 20% H ₂ O 61°C
Dimensions	14.55 x 12.62 x 11.82 in. HWD 37.0 x 32.0 x 30.0 cm
Weight	35 lbs 16.0 kg
Maximum Inlet Sample Temperature	400°F (205°C) SS, Glass Impingers 280°F (138°C) Kynar Impinger
Maximum Inlet Pressure	45 psig 3 bar / 2250 mmHg
Maximum Heat Exchanger Pressure Drop	<+1 in. H ₂ O
Ambient Temperature Range	33-104°F 0.56-40°C
Outlet Sample Gas Dew Point	41°F 5°C
Inlet Tubing Connection	3/8 in. FNPT
Outlet Tubing Connection	1/4 in. FNPT
Drain Tubing Connection	3/8 in. FNPT
Voltage	110 (220 optional) VAC 50/60 Hz
Thermoelectric Elements	40 mm
Power Supply	500W
Cooling Down Time	Less than 3 minutes

Baldwin™ is a Trademark of Perma Pure LLC
 Kynar® is a Registered Trademark of Alf Autochem of North America



REV#	DATE	DESCRIPTION	DRAWN	APPROVED
0	00/00/00	INITIAL DRAWING	JO	

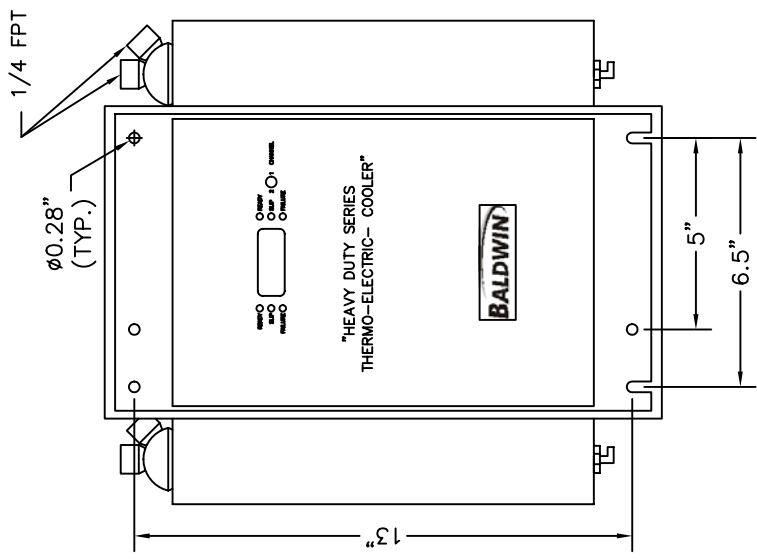

FRONT VIEW

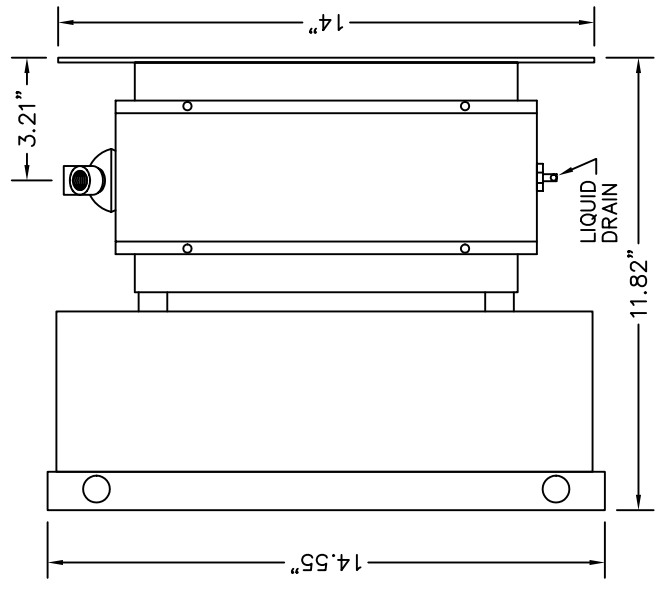

RIGHT SIDE VIEW

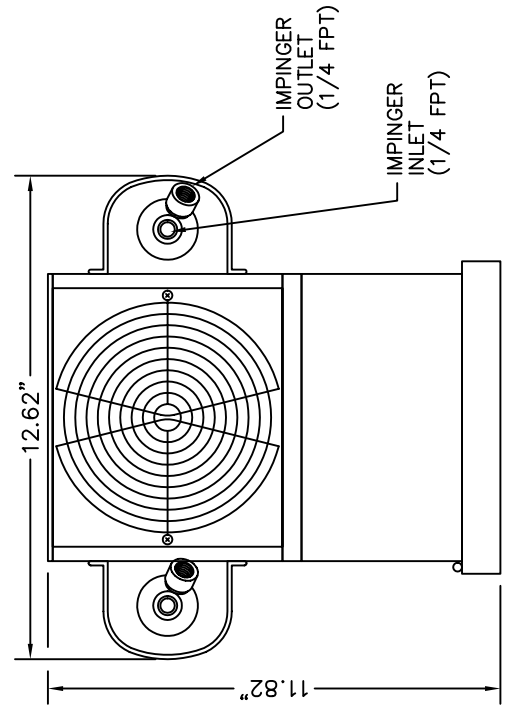

TOP VIEW

UNLESS OTHERWISE SPECIFIED	
TOLERANCE DECIMALS	FINISH
1 PLACE = ±.02	15
2 PLACE = ±.02	15
3 PLACE = ±.010	
ANGLES = ±5°	
HOLES = +.003/-001	
www.baldwinUSA.com	

PROPRIETARY INFORMATION
 THIS DOCUMENT CONTAINS PROPRIETARY INFORMATION OF BALDWIN, INC.
 AND IS TO BE USED SOLELY FOR THE PURPOSE FOR WHICH IT IS FURNISHED. THIS DOCUMENT SHALL NOT BE USED FOR ENGINEERING, DESIGN, PROCUREMENT, OR MANUFACTURING, IN WHOLE OR IN PART.
 BALDWIN, INC.

ITEM	QTY	DESCRIPTION	MANUF.
USED FOR:	MODEL NUMBER:		
DESCRIPTION:			
DRAWN BY:	DATE		
JO	05/12/02		
APP'D:	DATE		
MATERIAL:	PART DESCRIPTION		
AS NOTED	MODEL 8210 SAMPLE COOLER ARRANGEMENT DRAWING		
FINISH:	SIZE		
AS NOTED	A NTS		
DESIGN DIMENSIONS ARE IN INCHES	DRAWING/PART NO.:		
() DENOTES MILLIMETER EQUIVALENTS WHEN USED	A NTS		
	MODEL 8210		
	CAD DIR: S:\\$B&W\DWGS\T.E. COOL-HEAVY SERIES		
	SHEET 1 OF 1		

BALDWIN, INC.

MODEL 8210 SAMPLE COOLER ARRANGEMENT DRAWING

MODEL 8210

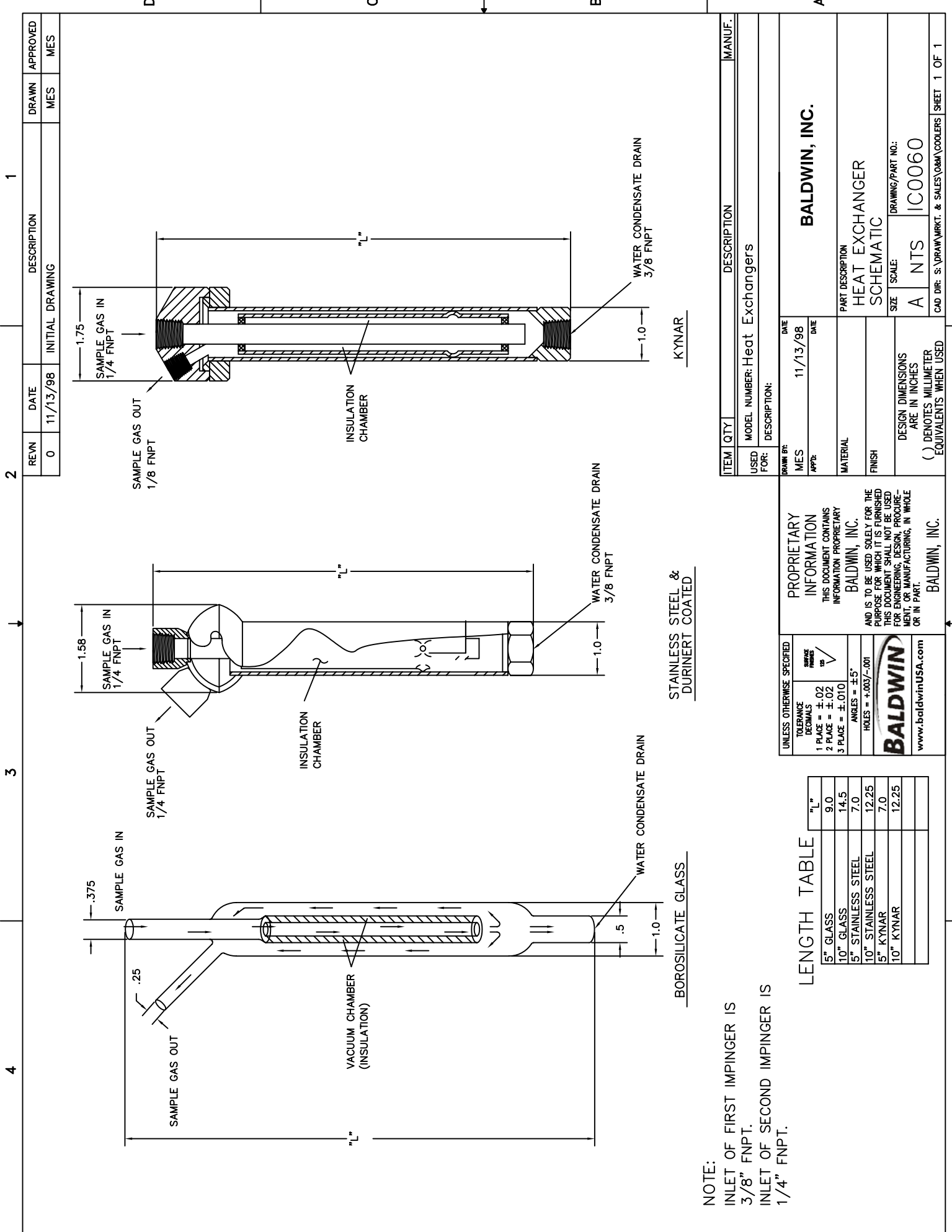

REV#	DATE	DESCRIPTION	DRAWN	APPROVED
0	11/13/98	INITIAL DRAWING	MES	MES

ITEM	QTY	DESCRIPTION	MANUF.
USED FOR:		MODEL NUMBER: Heat Exchangers	
DESCRIPTION:			
DRAWN BY:	DATE		
MES	11/13/98		
APP#:	DATE		
MATERIAL			
FINISH			
DESIGN DIMENSIONS ARE IN INCHES	SIZE	DRAWING/PART NO.:	
() DENOTES MILLIMETER EQUIVALENTS WHEN USED	A	NTS	IC0060
			CAD DIR: S:\DRAW\MRKT. & SALES\OBAM\COOLERS

PROPRIETARY INFORMATION
 THIS DOCUMENT CONTAINS INFORMATION PROPRIETARY TO **BALDWIN, INC.**
 AND IS TO BE USED SOLELY FOR THE PURPOSE FOR WHICH IT IS FURNISHED. THIS DOCUMENT SHALL NOT BE USED FOR ENGINEERING, DESIGN, PROCUREMENT, OR MANUFACTURING, IN WHOLE OR IN PART.
BALDWIN, INC.
 www.baldwinUSA.com

UNLESS OTHERWISE SPECIFIED

TOLERANCE DECIMALS	
1 PLACE = ±.02	
2 PLACE = ±.02	
3 PLACE = ±.010	
ANGLES = ±5°	
HOLES = +.003/- .001	

BALDWIN
www.baldwinUSA.com

LENGTH TABLE

5" GLASS	9.0
10" GLASS	14.5
5" STAINLESS STEEL	7.0
10" STAINLESS STEEL	12.25
5" KYNAR	7.0
10" KYNAR	12.25

NOTE:
 INLET OF FIRST IMPINGER IS 3/8" FNPT.
 INLET OF SECOND IMPINGER IS 1/4" FNPT.

REV#	DATE	DESCRIPTION	DRAWN	APPROVED
0	00/00/00	INITIAL DRAWING	LD	RD

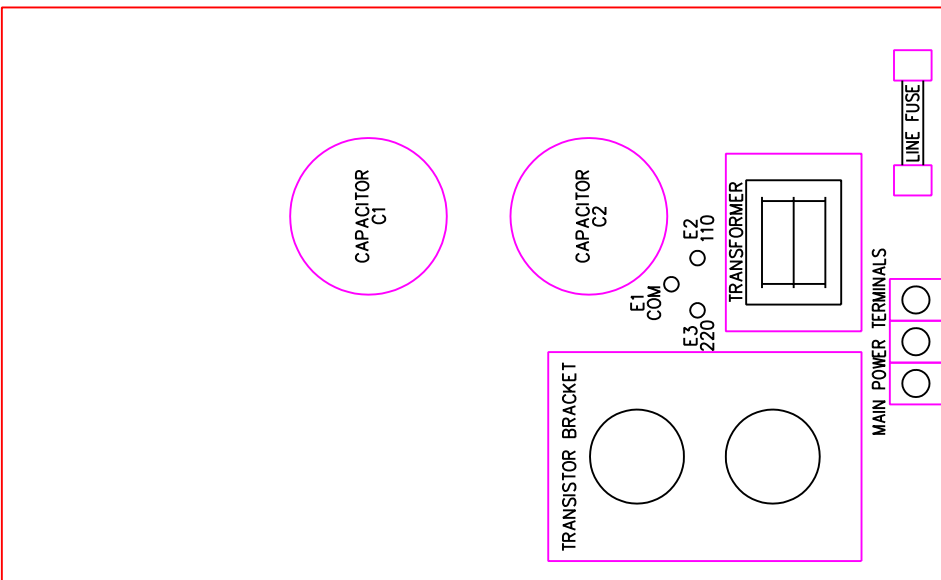

POWER SUPPLY MAINS JUMPER PROCEDURE:

1. FOR 110VAC 60Hz JUMPER COMMON (E1) TO 110 (E2).
2. FOR 220VAC 50Hz JUMPER COMMON (E1) TO 220 (E3).

NOTE:
CUT VALUE OF FUSE IN HALF WHEN SWITCHING FROM 110 VAC TO 220 VAC

ITEM	QTY	DESCRIPTION	MANUF.
USED FOR:		MODEL NUMBER: All Baldwin Thermo-Electric Coolers	
DESCRIPTION:		POWER SUPPLY	
DRAWN BY:	DATE	PART DESCRIPTION	
RAW	04/28/97	POWER SUPPLY MAINS JUMPER CONFIGURATION	
APPR:		SIZE	DRAWING/PART NO:
		A	NTS 5C-P JUMP
MATERIAL		CAD DIR: S:\DRAW\SCHEMATICS\ELECTRICAL	
FINISH		SHEET 1 OF 1	
DESIGN DIMENSIONS ARE IN INCHES () DENOTES MILLIMETER EQUIVALENTS WHEN USED		BALDWIN, INC.	
PROPRIETARY INFORMATION THIS DOCUMENT CONTAINS INFORMATION PROPRIETARY TO BALDWIN, INC. AND IS TO BE USED SOLELY FOR THE PURPOSE FOR WHICH IT IS FURNISHED. THIS DOCUMENT SHALL NOT BE USED FOR ENGINEERING, DESIGN, PROCUREMENT, OR MANUFACTURING, IN WHOLE OR IN PART.		BALDWIN, INC.	
UNLESS OTHERWISE SPECIFIED: TOLERANCE DECIMALS 1 PLACE = ± .02 2 PLACE = ± .02 3 PLACE = ± .010 ANGLES = ± 5° HOLES = +.003/- .001		BALDWIN www.baldwinUSA.com	

REV#	DATE	DESCRIPTION	DRAWN	APPROVED
0	00/00/00	INITIAL DRAWING	LD	RD

METER CALIBRATION
REF TP1 - .04VDC = 4°C

S1 (2 CHANNEL UNIT ONLY)
(FRONT SIDE OF BOARD)
RIGHT - CHANNEL 1
LEFT - CHANNEL 2

CHANNEL 1 ADJUSTMENT TEST PTS
REF. TO VDC_GRD 0.01VDC/°C
TP1 ZERO/SPAN ADJUSTMENT
TP2 SET OPERATING TEMPERATURE
TP3 SET READY TEMPERATURE

CHANNEL 1
K TYPE THERMOCOUPLE INPUT
CHANNEL 1 - IMPINGER TEMP

CH 1 SET POINT (5°C/0.05VDC @ TP2)
CH 1 READY SET POINT (10°C/0.10VDC @ TP3)

CH 1 SAMPLE CHILLER ZERO/SPAN
RANGE OF CALIBRATION 0°C-25°C
ADJUST @ TP1

GROUND FROM POWER SUPPLY

CHANNEL 2 ADJUSTMENT TEST PTS
REF. TO VDC_GRD 0.01VDC/°C
TP4 ZERO/SPAN ADJUSTMENT
TP5 SET OPERATING TEMPERATURE
TP6 SET READY TEMPERATURE

TEMPERATURE OUTPUT
TG - GROUND
T2 - (OPTIONAL NJ) CHANNEL 2 CONTROL TEMP. 0.1VDC
T1 - (STANDARD) CHANNEL 1 CONTROL TEMP. 0.01VDC/°C

CHANNEL 2 OR SAMPLE TEMP OPTION
K TYPE THERMOCOUPLE INPUT
2 CHANNEL SYSTEM - IMPINGER TEMP OR
OPTIONAL NJ SYSTEM - EXITING SAMPLE TEMP.

CH 2 SET POINT (5°C/0.05VDC @ TP5)
CH 2 READY SET POINT (10°C/0.10VDC @ TP6)

SPAN }
CH 2 SAMPLE CHILLER ZERO/SPAN
RANGE OF CALIBRATION 0°C-25°C
ZERO } ADJUST @ TP4

+15VDC (14.72VDC) FROM POWER SUPPLY

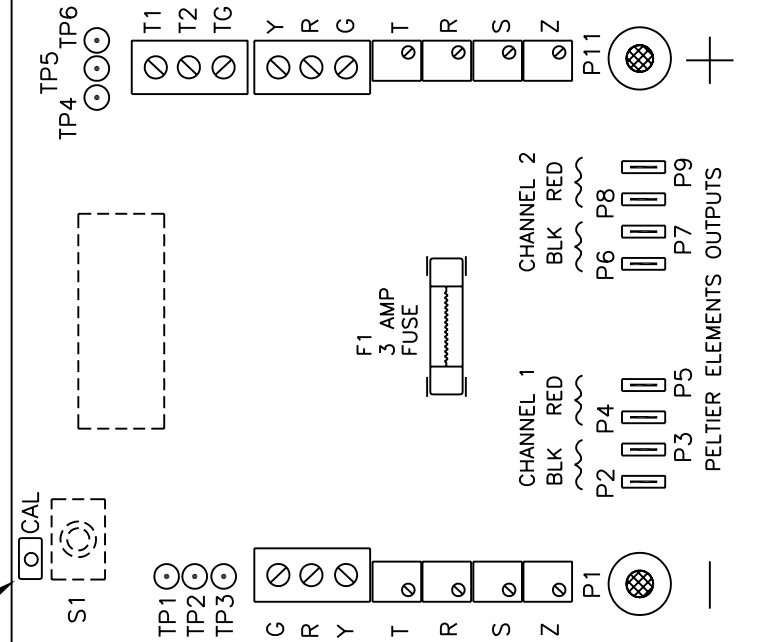

ITEM	QTY	DESCRIPTION	MANUF.
USED FOR:		MODEL NUMBER: 8210 & 20410	
DESCRIPTION:			

DATE	04/10/97
LD	
DATE	
MATERIAL	
FINISH	
DESIGN DIMENSIONS ARE IN INCHES	
() DENOTES MILLIMETER EQUIVALENTS WHEN USED	

PROPRIETARY INFORMATION
THIS DOCUMENT CONTAINS INFORMATION PROPRIETARY TO BALDWIN, INC.

AND IS TO BE USED SOLELY FOR THE PURPOSE FOR WHICH IT IS FURNISHED. THIS DOCUMENT SHALL NOT BE USED FOR ENGINEERING, DESIGN, PROCUREMENT, OR MANUFACTURING, IN WHOLE OR IN PART.

BALDWIN
www.baldwinUSA.com

UNLESS OTHERWISE SPECIFIED	
TOLERANCE DECIMALS	FRACTIONS
1 PLACE = ±.02	15
2 PLACE = ±.02	
3 PLACE = ±.010	
ANGLES = ±5°	
HOLES = +.003/- .001	
BALDWIN, INC.	
TEMPERATURE CONTROL BOARD ARRANGEMENT DRAWING	
SIZE	DRAWING/PART NO.
A	NTS 3CCB-011
CAD DIR: S:\DRAW\SCHEMATICS\ELECTRICAL	
SHEET 1 OF 1	

REV#	DATE	DESCRIPTION	DRAWN	APPROVED
0	00/00/00	INITIAL DRAWING		

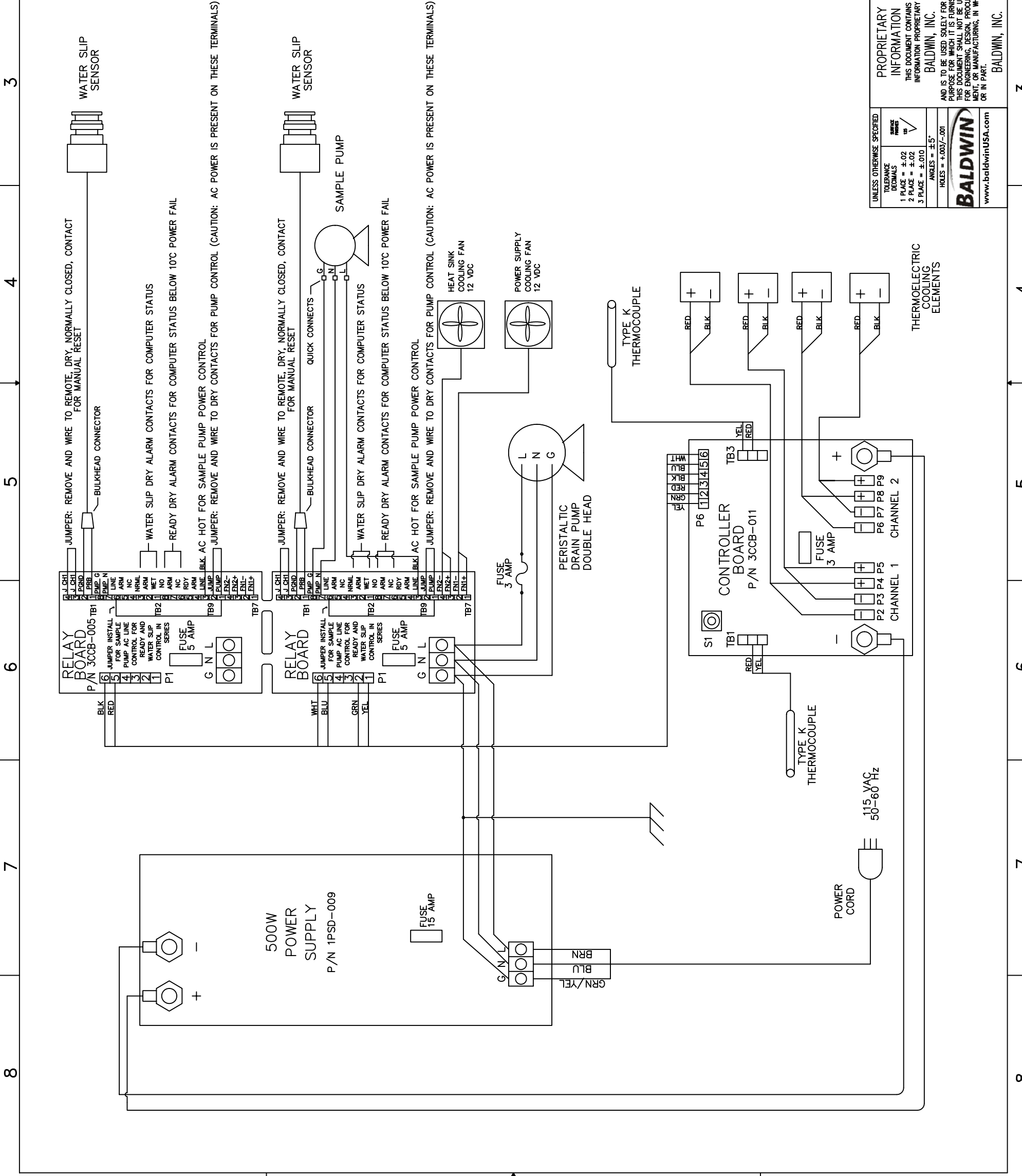

ITEM	QTY	DESCRIPTION	MANUF.
USED FOR:	MODEL NUMBER: 8210, 20410	DESCRIPTION: THERMO-ELECTRIC COOLER	
LD APPR:	DATE: 04/30/97		
MATERIAL:			
FINISH:			
DESIGN DIMENSIONS ARE IN INCHES		PART DESCRIPTION	
() DENOTES MILLIMETER EQUIVALENTS WHEN USED		FOUR PELTIER, DUAL CHANNEL INTERCONNECT DIAGRAM	
SIZE	B NTS	DRAWING/PART NO:	IDC2C4P
CAD DIR:	S:\DRAW\SCHMATICS\ELECTRICAL		

PROPRIETARY INFORMATION
 THIS DOCUMENT CONTAINS INFORMATION PROPRIETARY TO
BALDWIN, INC.
 AND IS TO BE USED SOLELY FOR THE PURPOSE FOR WHICH IT IS FURNISHED. THIS DOCUMENT, SPECIFICATIONS, DRAWINGS, PARTS LIST, AND MANUFACTURING INFORMATION IS NOT TO BE REPRODUCED, COPIED, OR TRANSMITTED IN ANY FORM OR BY ANY MEANS, ELECTRONIC OR MECHANICAL, INCLUDING PHOTOCOPYING, RECORDING, OR BY ANY INFORMATION STORAGE AND RETRIEVAL SYSTEM.

BALDWIN
 www.baldwinUSA.com

UNLESS OTHERWISE SPECIFIED:
 TOLERANCE DECIMALS
 1 PLACE = ±.02
 2 PLACE = ±.02
 3 PLACE = ±.010
 ANGLES = ±5°
 HOLES = +.003/- .001

THERMOELECTRIC COOLING ELEMENTS	
+	-
+	-
+	-
+	-
POWER CORD 115 VAC 50-60 Hz	

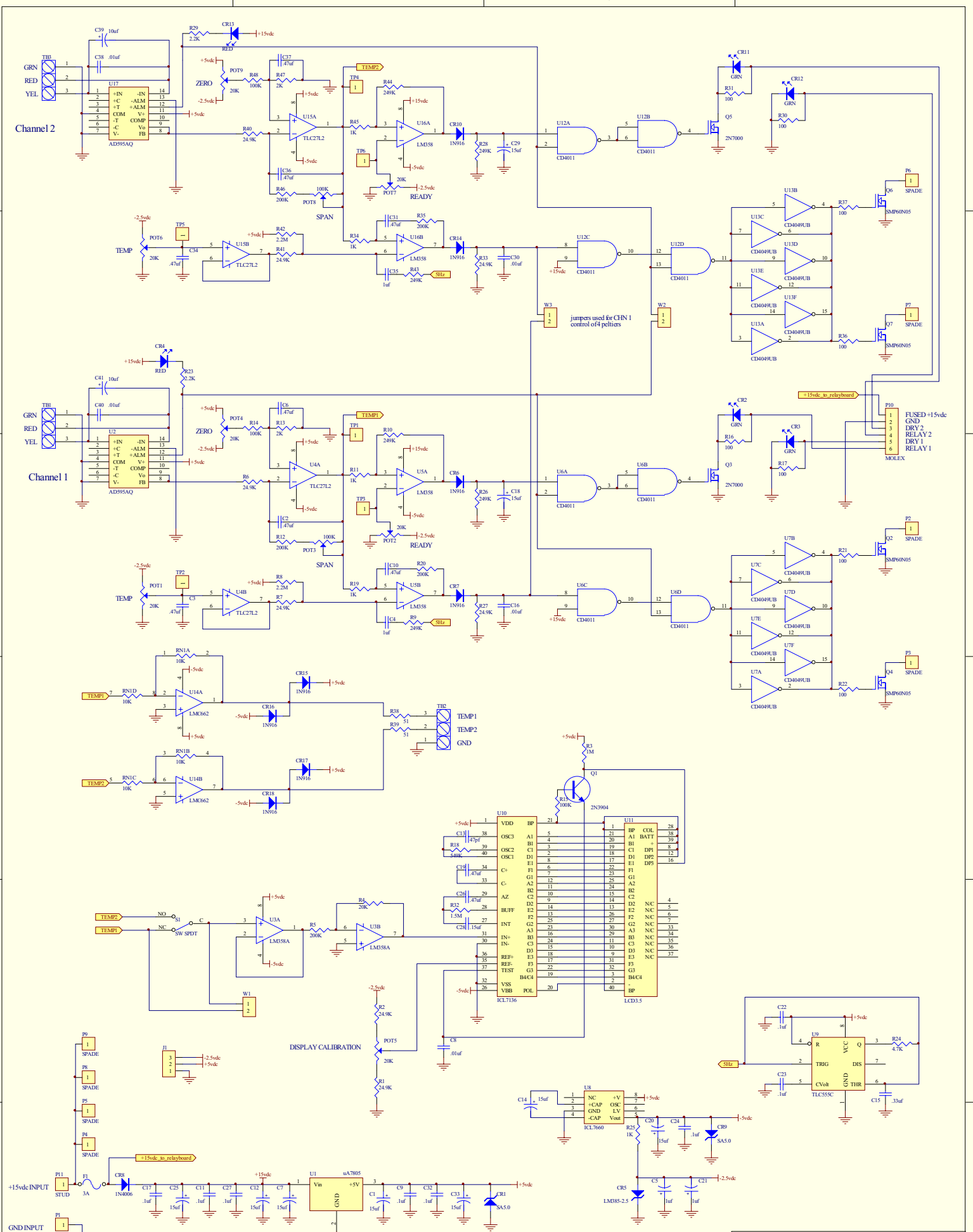

Company			
Baldwin Environmental			
Title			
Sample Cooler Controller			
Size	Number	ASSY.PN 3CCB-011	Revision
C			2.30
Date:	15-Aug-2001	Sect Inf	1
File:	C:\PROGRAMS-1\3CCB011A.SCH	Drawn By:	

Note: PCB PN 1CDB-004

REV#	DATE	DESCRIPTION	DRAWN	APPROVED
0	00/00/00	INITIAL DRAWING	RAW	RAW

ITEM	QTY	DESCRIPTION	MANUF.
USED FOR:		MODEL NUMBER: 8210, 20410	
DRAWN BY:		DATE	
RAW APP'D:		01/13/04	
MATERIAL:			
FINISH:			
DESIGN DIMENSIONS ARE IN INCHES		PART DESCRIPTION	
() DENOTES MILLIMETER EQUIVALENTS WHEN USED		DUAL RELAY ALARM BOARD FIELD CONNECTIONS	
SIZE	SCALE:	DRAWING/PART NO:	
A	NTS	3CCB-005	
CAD DIR: S:\DRAW\SCHEMATICS\ELECTRICAL			SHEET 1 OF 1

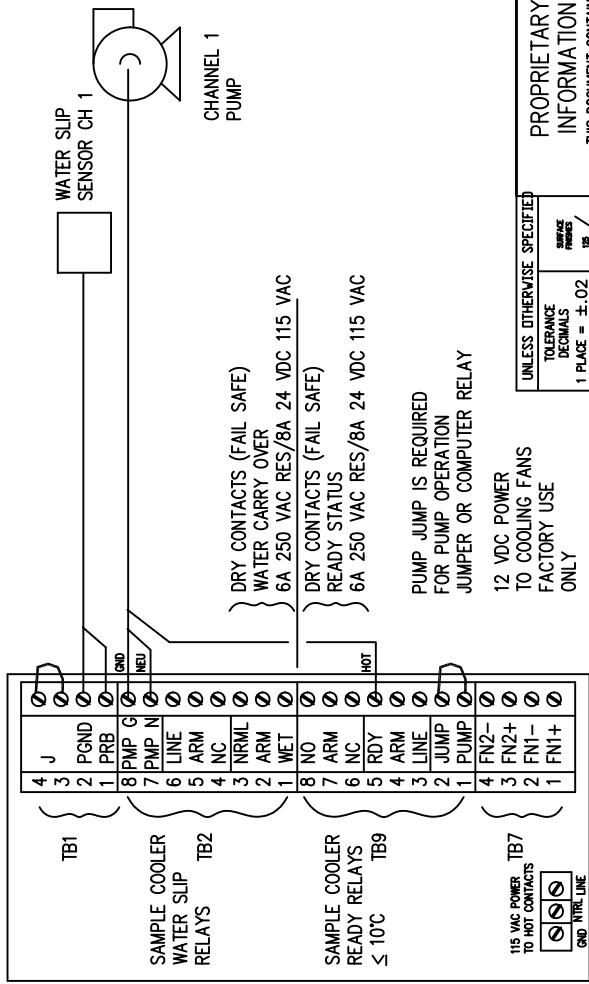
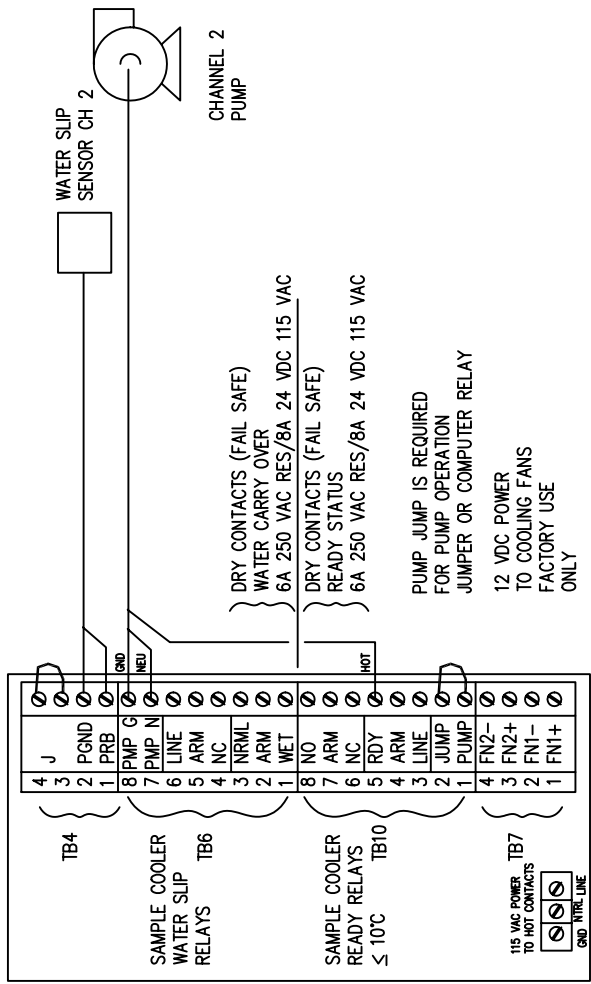

UNLESS OTHERWISE SPECIFIED

TOLERANCE DECIMALS	1 PLACE = ±.02
2 PLACE = ±.02	
3 PLACE = ±.010	

ANGLES = ±5°
HOLES = +.003/-001

BALDWIN
www.baldwinUSA.com

PROPRIETARY INFORMATION
THIS DOCUMENT CONTAINS INFORMATION PROPRIETARY TO BALDWIN, INC.
AND IS TO BE USED SOLELY FOR THE PURPOSE FOR WHICH IT IS FURNISHED. THIS DOCUMENT SHALL NOT BE USED FOR ENGINEERING, DESIGN, PROCUREMENT, OR MANUFACTURING, IN WHOLE OR IN PART.
BALDWIN, INC.

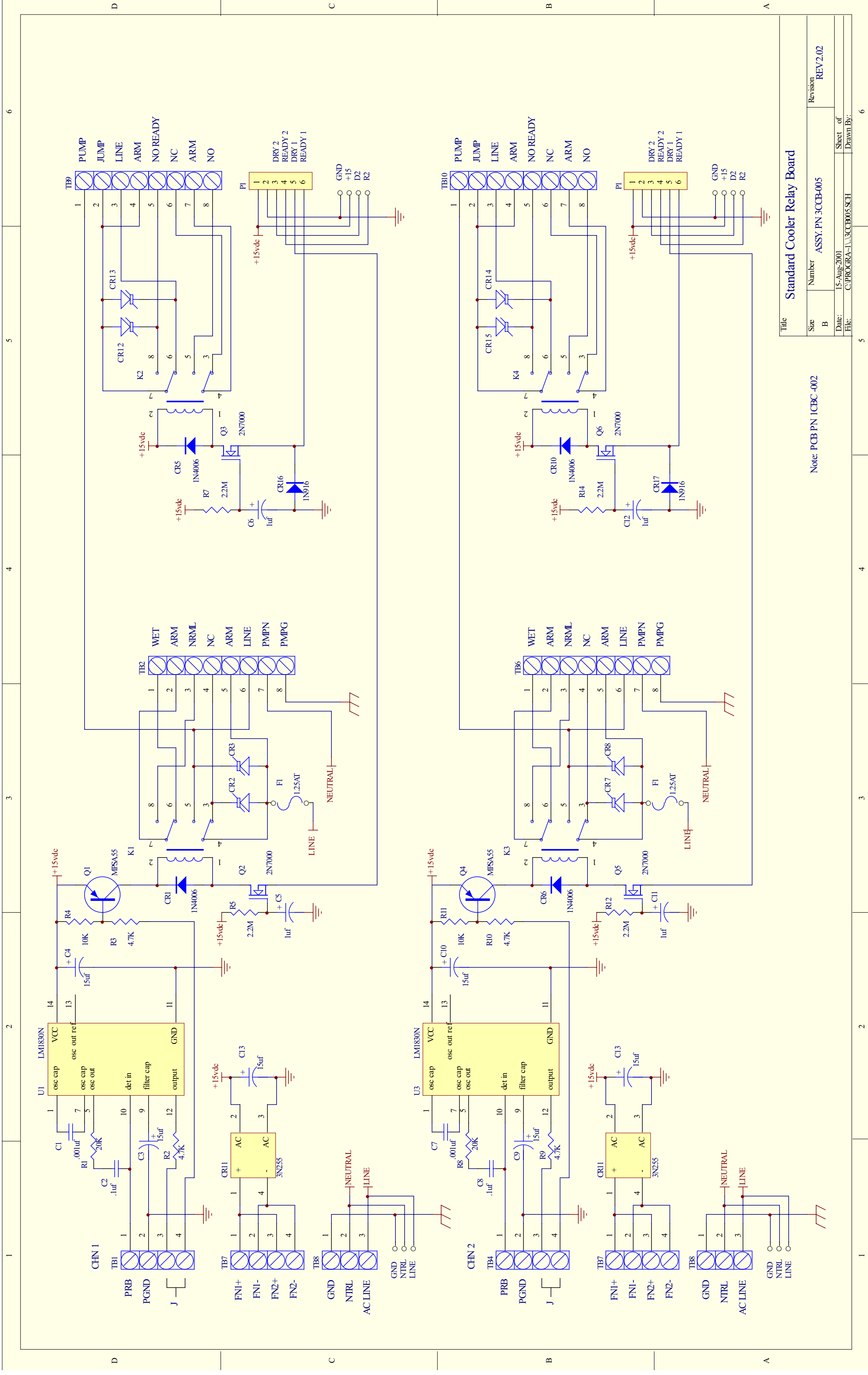

Standard Cooler Relay Board

Note: PCB PN ICBC-002

Title	Number	Revision
Size	ASSY: PN 3CCB-005	REV 2.02
Date:	15-Aug-2001	Sheet of
File:	C:\PROGRA~1\3CCB005\SCH	Drawn By:

**CONTACT STATES
POWER ALARM
SHELF ON**

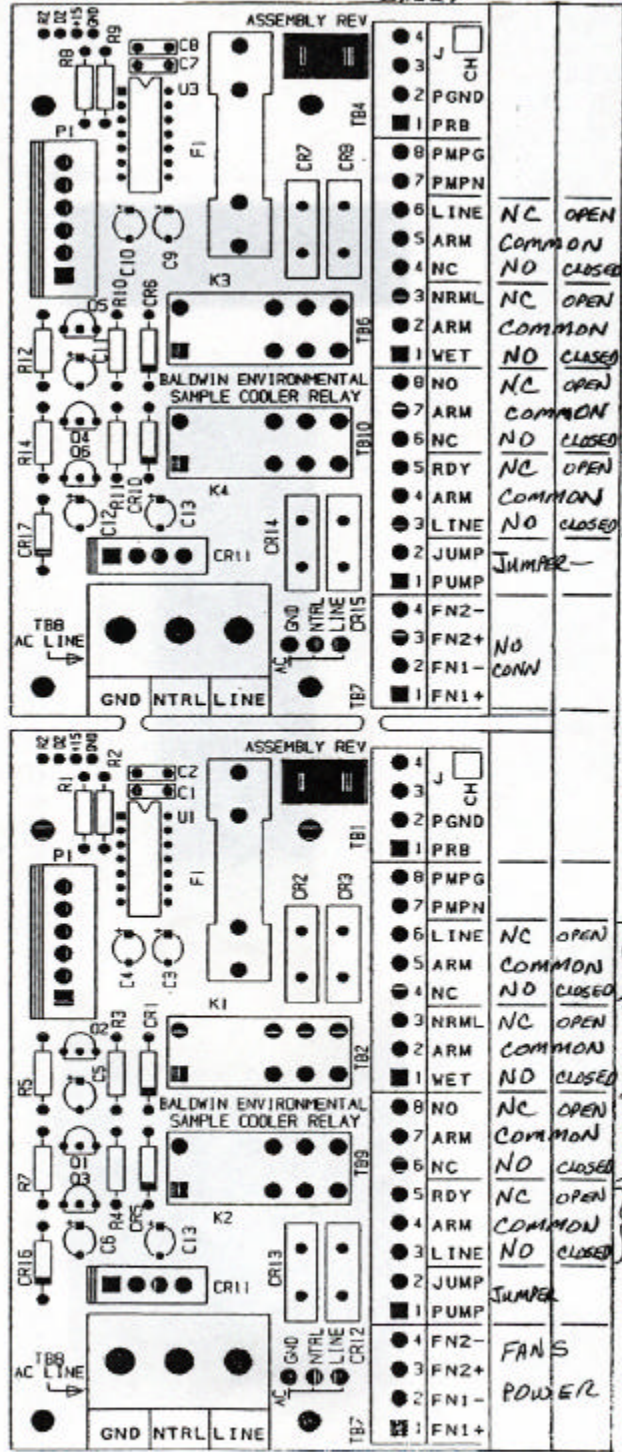

AC PUMP CONTROL CHANNEL #2
 DRY COMPUTER ALARM
 STATUS READY TEMPERATURE ALARM
 AC POWER PUMP CONTROL

AC PUMP CONTROL CHANNEL #1
 DRY COMPUTER ALARM
 STATUS READY TEMPERATURE ALARM
 AC POWER PUMP CONTROL

3. ASSUME PHS unless otherwise specified.
 2. Verify LED indicator of components on P.C.B. shall not extend more than 1/8" from P.C.B.
 1. Components are identified by part number reference designations in parts list.
 ALL DIMENSIONS ARE IN INCHES UNLESS OTHERWISE SPECIFIED.
 NOTES UNLESS OTHERWISE SPECIFIED:

BALDWIN ENVIRONMENTAL INC.
 BALDWIN ENVIRONMENTAL DIVISION
 1000 W. 10TH AVE., SUITE 1
 DENVER, CO. 80202-2500
 TEL: 303-751-4400
 FAX: 303-751-4401

ASSEMBLY P.C.B.
 SAMPLE RELAY BOARD

REV. 1.0
 DATE: 10/21/83

APPENDIX B: SAMPLE CONDITIONING SYSTEM

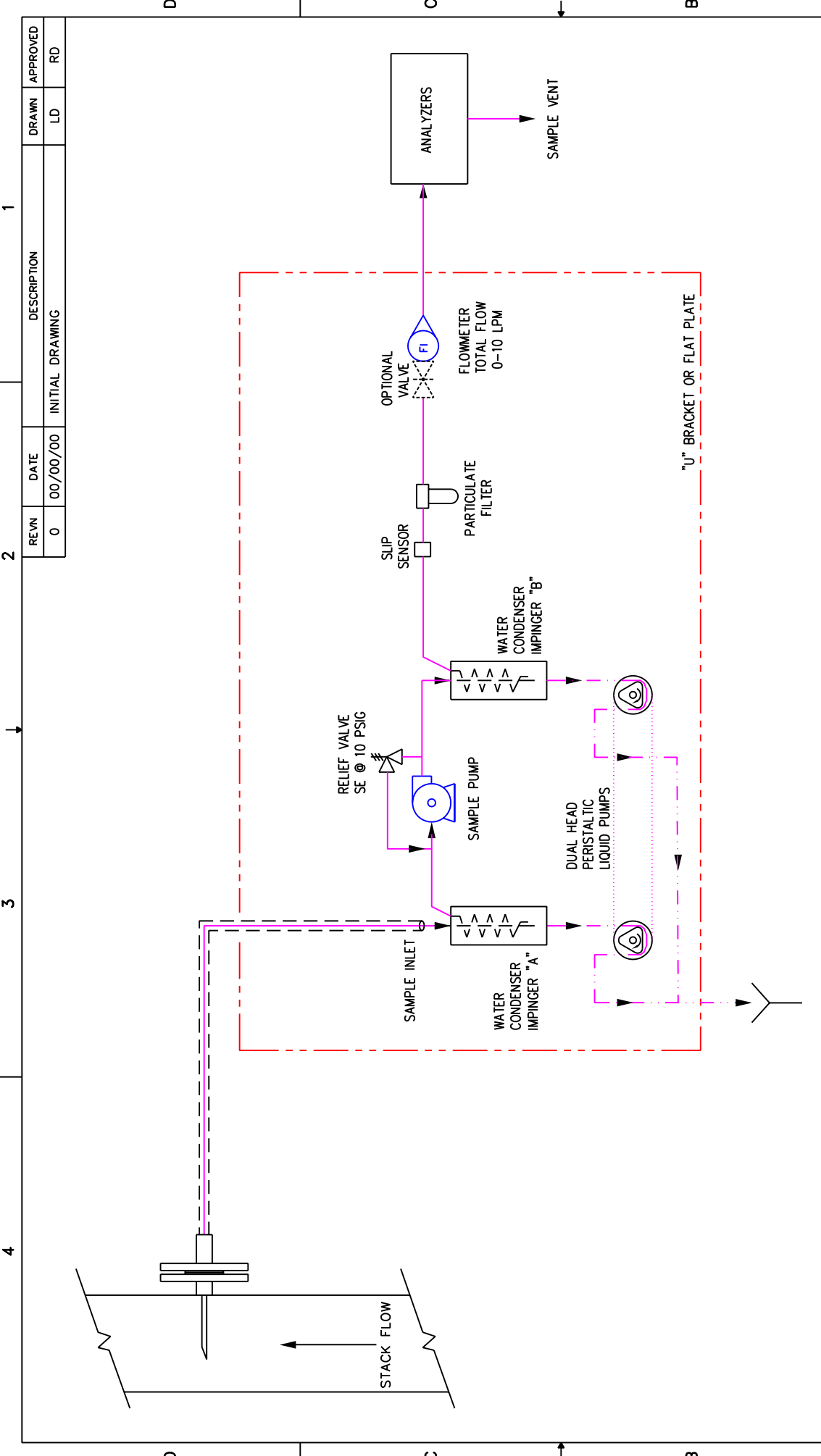

ITEM	QTY	DESCRIPTION	MANUF.
USED FOR:		MODEL NUMBER: M425, 8210	
DESCRIPTION:			

DRWN BY: MES	DATE:
APP'D:	DATE:
MATERIAL:	
FINISH:	
DESIGN DIMENSIONS ARE IN INCHES () DENOTES MILLIMETER EQUIVALENTS WHEN USED	
PART DESCRIPTION	
ACTIVE/ACTIVE SAMPLE CONDITIONING SYSTEM FLOW DIA.	
SIZE	SCALE:
A	NTS
ACTIVE/ACTIVE	

PROPRIETARY INFORMATION
 THIS DOCUMENT CONTAINS INFORMATION PROPRIETARY TO BALDWIN, INC.
 AND IS TO BE USED SOLELY FOR THE PURPOSE FOR WHICH IT IS FURNISHED. THIS DOCUMENT SHALL NOT BE USED FOR ENGINEERING, DESIGN, PROCUREMENT, OR MANUFACTURING, IN WHOLE OR IN PART.
 BALDWIN, INC.
 www.baldwinUSA.com

UNLESS OTHERWISE SPECIFIED	
TOLERANCE DECIMALS	FINISH
1 PLACE = ± .02	15
2 PLACE = ± .02	
3 PLACE = ± .010	
ANGLES = ± 5°	
HOLES = +.003/- .001	

- NOTES:**
- ALL COMPONENTS WETTED BY SAMPLE AND CALIBRATION GASES SHALL BE STAINLESS STEEL, BOROSILICATE GLASS, TEFLON OR VITON.
 - TOTAL FLOW SHALL BE RATED CAPACITY OF SAMPLE CHILLER.

REV#	DATE	DESCRIPTION	DRAWN	APPROVED
0	00/00/00	INITIAL DRAWING	RAW	RAW

1	2	3	4	5	6	7	8
---	---	---	---	---	---	---	---

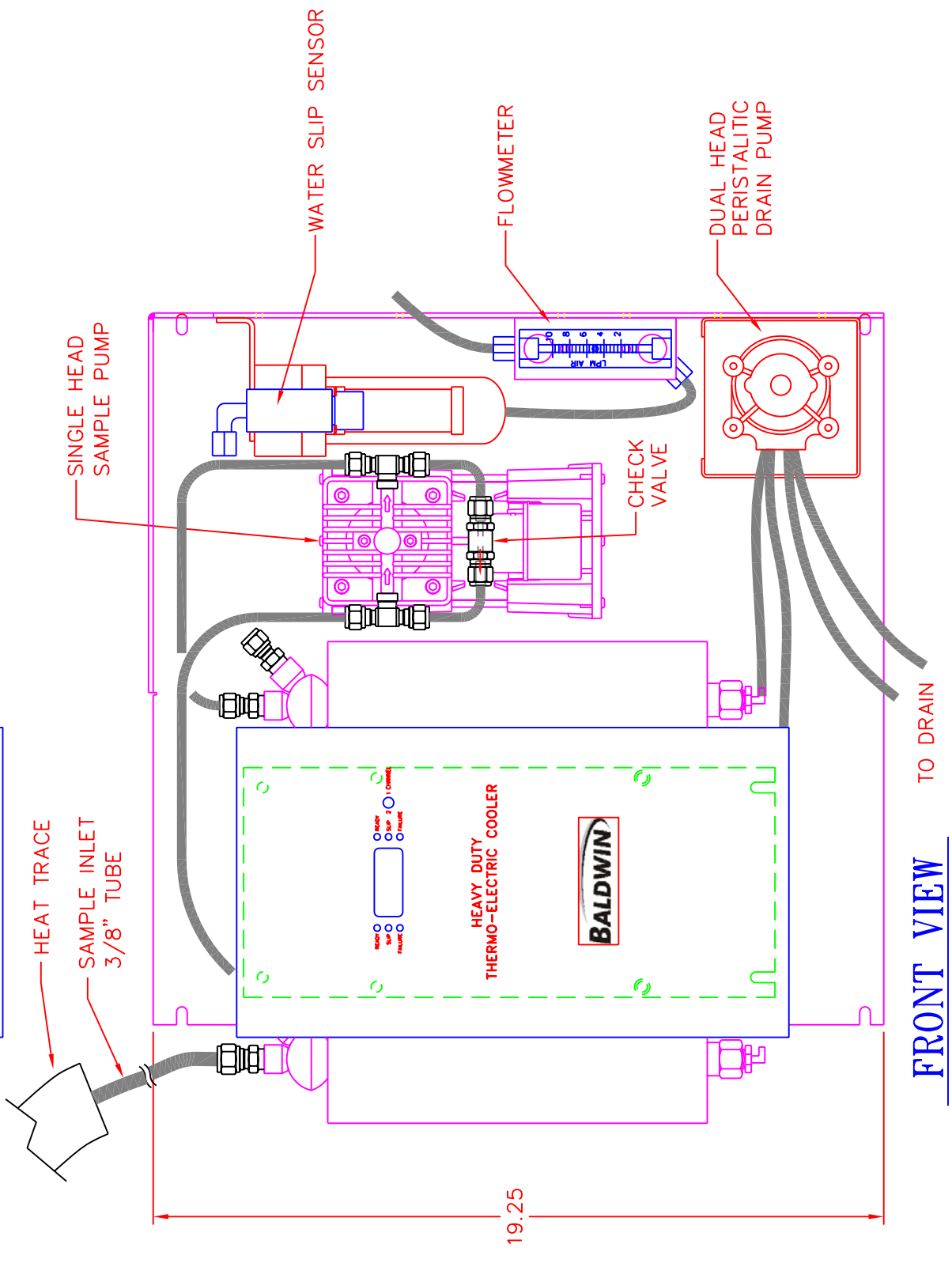
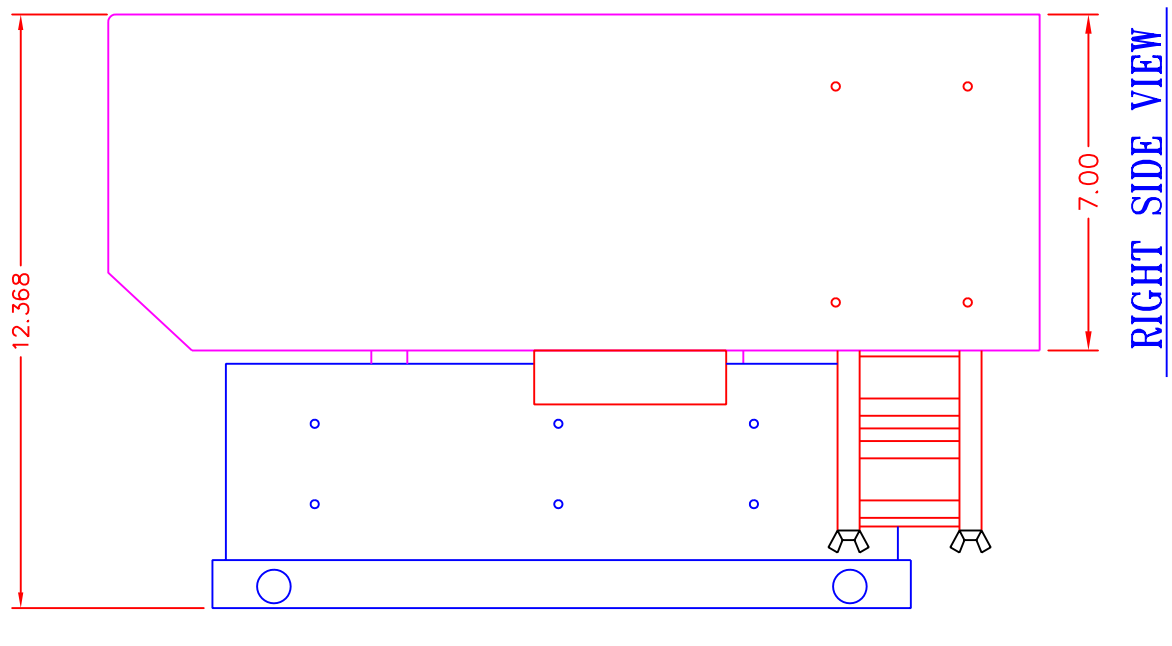
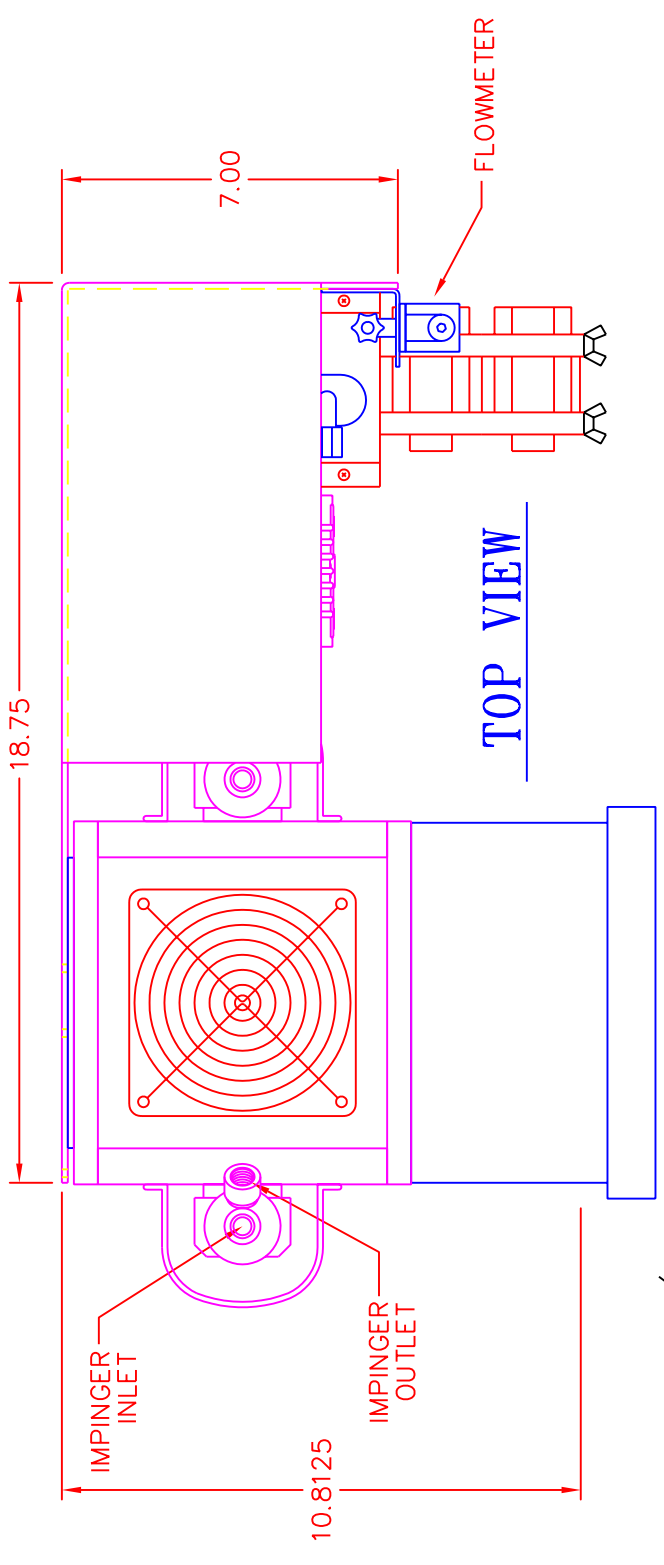

ITEM	QTY	DESCRIPTION	MANUF.
MODEL NUMBER: 04/21/04			
DESCRIPTION: 04/21/04			
DRAWING/PART NO. BALDWIN, INC.			
PART DESCRIPTION MODEL 4S-8210-9EC1			
SAMPLE CONDITIONING SYSTEM			
SIZE SCALE: B 1/4			
DRAWING/PART NO. 4S-8210-9EC1			
CAD DIR: S:\S&M\DWGS\S&M_CON_SYSTEM\DWG_SHEET_1_OF_1			
DESIGN DIMENSIONS ARE IN INCHES			
() DENOTES MILLIMETER EQUIVALENTS WHEN USED			
MATERIAL			
FINISH			
UNLESS OTHERWISE SPECIFIED			
TOLERANCE DECIMALS			
1 PLACE = ±.02			
2 PLACE = ±.02			
3 PLACE = ±.010			
ANGLES = ±5°			
HOLES = ±.007/- .001			
SURFACE FINISH			
10			
BALDWIN			
www.baldwinUSA.com			

D	C	B	A
---	---	---	---

1	2	3	4	5	6	7	8
---	---	---	---	---	---	---	---

REV#	DATE	DESCRIPTION	DRAWN	APPROVED
0	00/00/00	INITIAL DRAWING	RAW	RAW

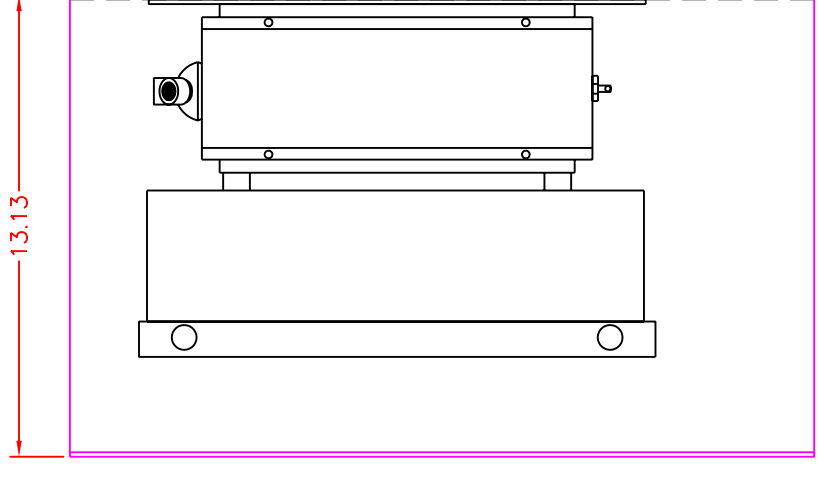
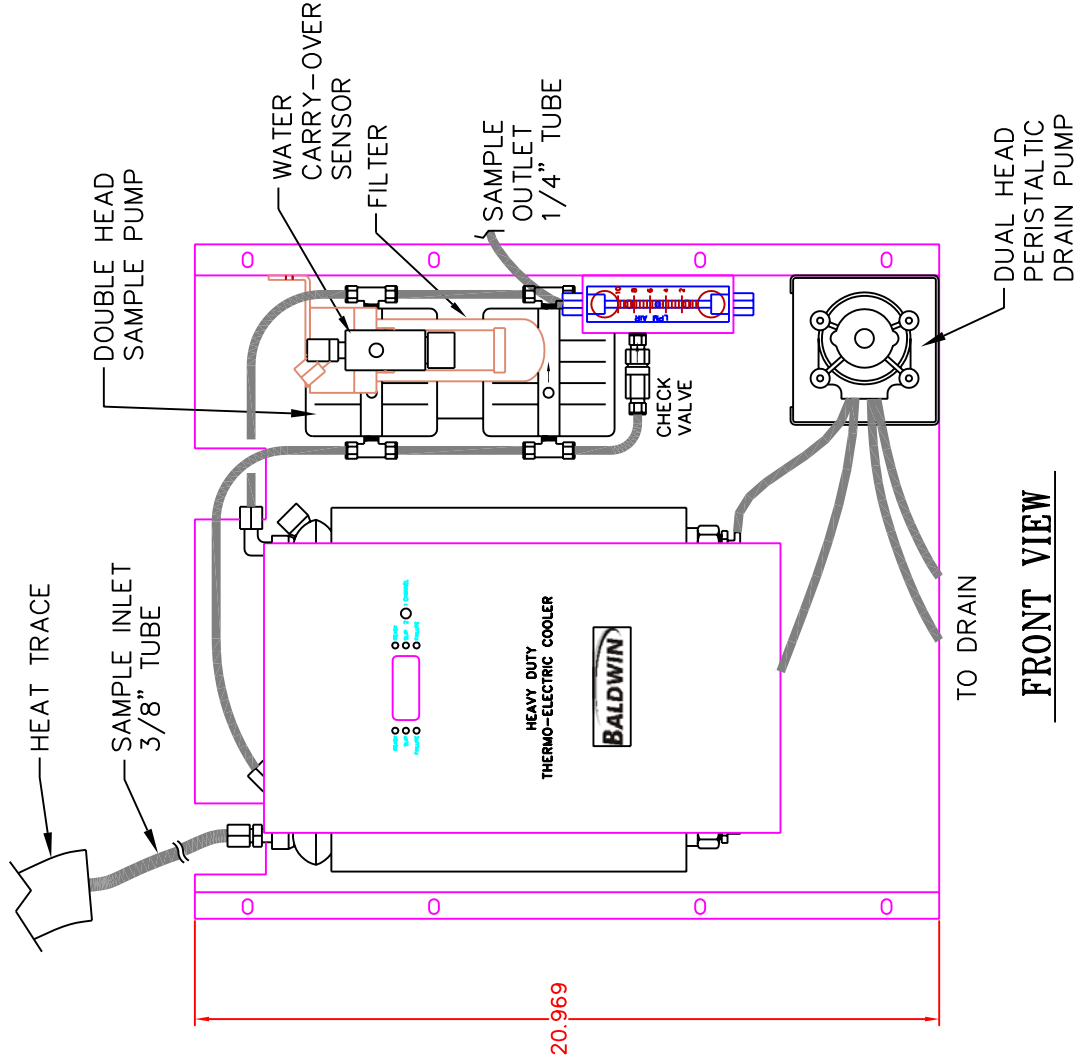
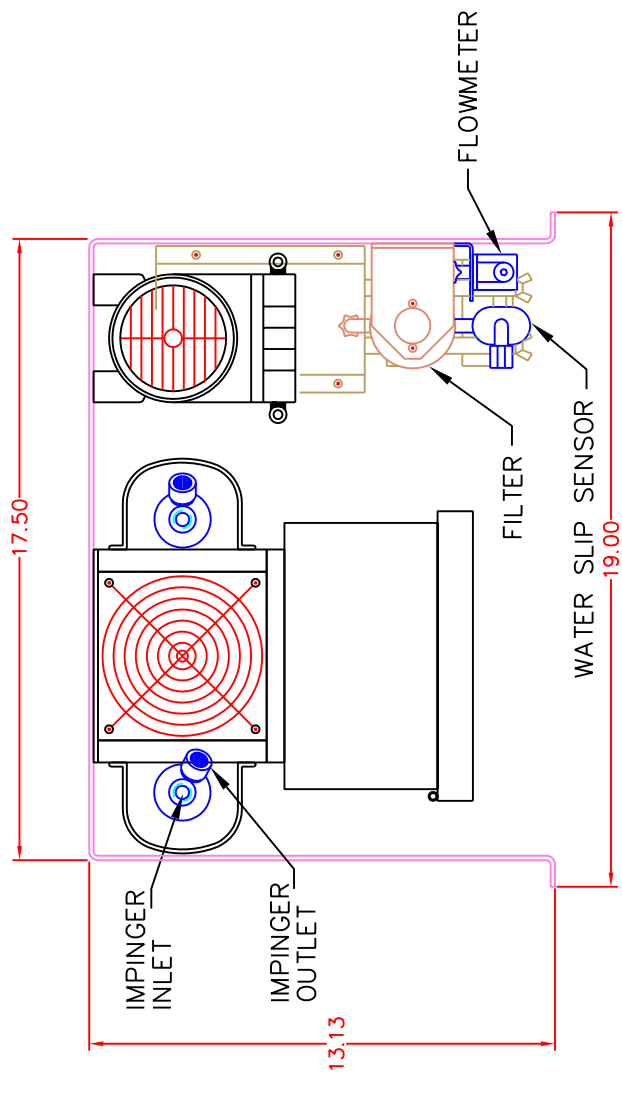

UNLESS OTHERWISE SPECIFIED
 TOLERANCE DECIMALS
 1 PLACE = ±.02
 2 PLACE = ±.02
 3 PLACE = ±.010
 ANGLES = ±5'
 HOLES = ±.007/- .001

PROPRIETARY INFORMATION
 THIS DOCUMENT CONTAINS INFORMATION PROPRIETARY TO BALDWIN, INC.
 AND IS TO BE USED SOLELY FOR THE PURPOSE FOR WHICH IT IS FURNISHED HEREON. IT SHALL NOT BE USED FOR OTHER PURPOSES, REPRODUCTION, OR MANUFACTURING, IN WHOLE OR IN PART.
 BALDWIN, INC.
 www.baldwinUSA.com

ITEM	QTY	DESCRIPTION	MANUF.
MODEL NUMBER: _____			
USED FOR: _____			
DESCRIPTION: _____			
DRAWN BY:	DATE	DATE	
RAW	04/21/04		
APPR:			
PART DESCRIPTION			
MODEL 4S-8210-9BCD			
SAMPLE CONDITIONING SYSTEM			
SIZE	SCALE:	DRAWING/PART NO.:	
B	1/8	4S-8210-9BCD	
DESIGN DIMENSIONS ARE IN INCHES			
() DENOTES MILLIMETER EQUIVALENTS WHEN USED			
CAD DIR: S:\S&M\DWGS\S&M_COND_SYSTEM\DWG_SHEET_1_OF_1			

REV#	DATE	DESCRIPTION	DRAWN	APPROVED
0	00/00/00	INITIAL DRAWING	RAW	RAW

1	2	3	4	5	6	7	8
---	---	---	---	---	---	---	---

D C B A

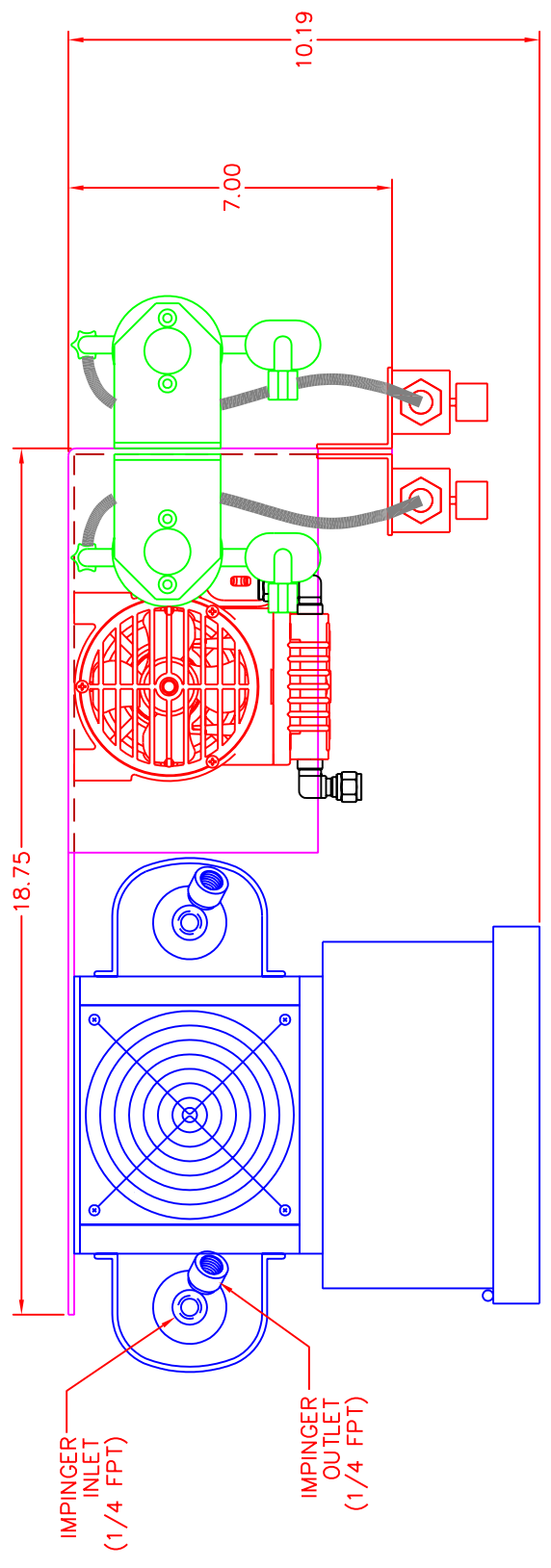

TOP VIEW

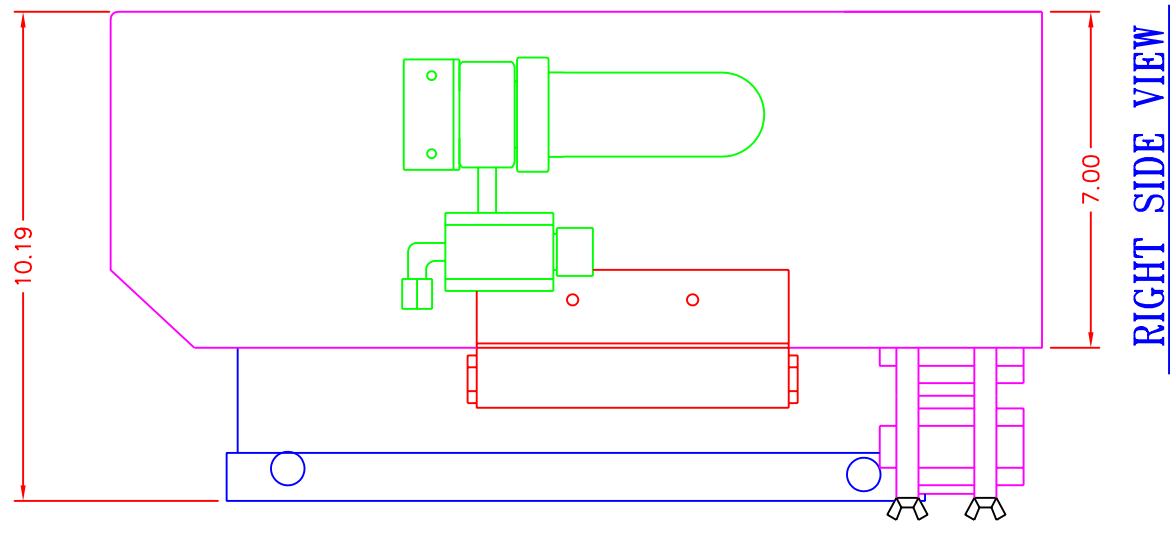

RIGHT SIDE VIEW

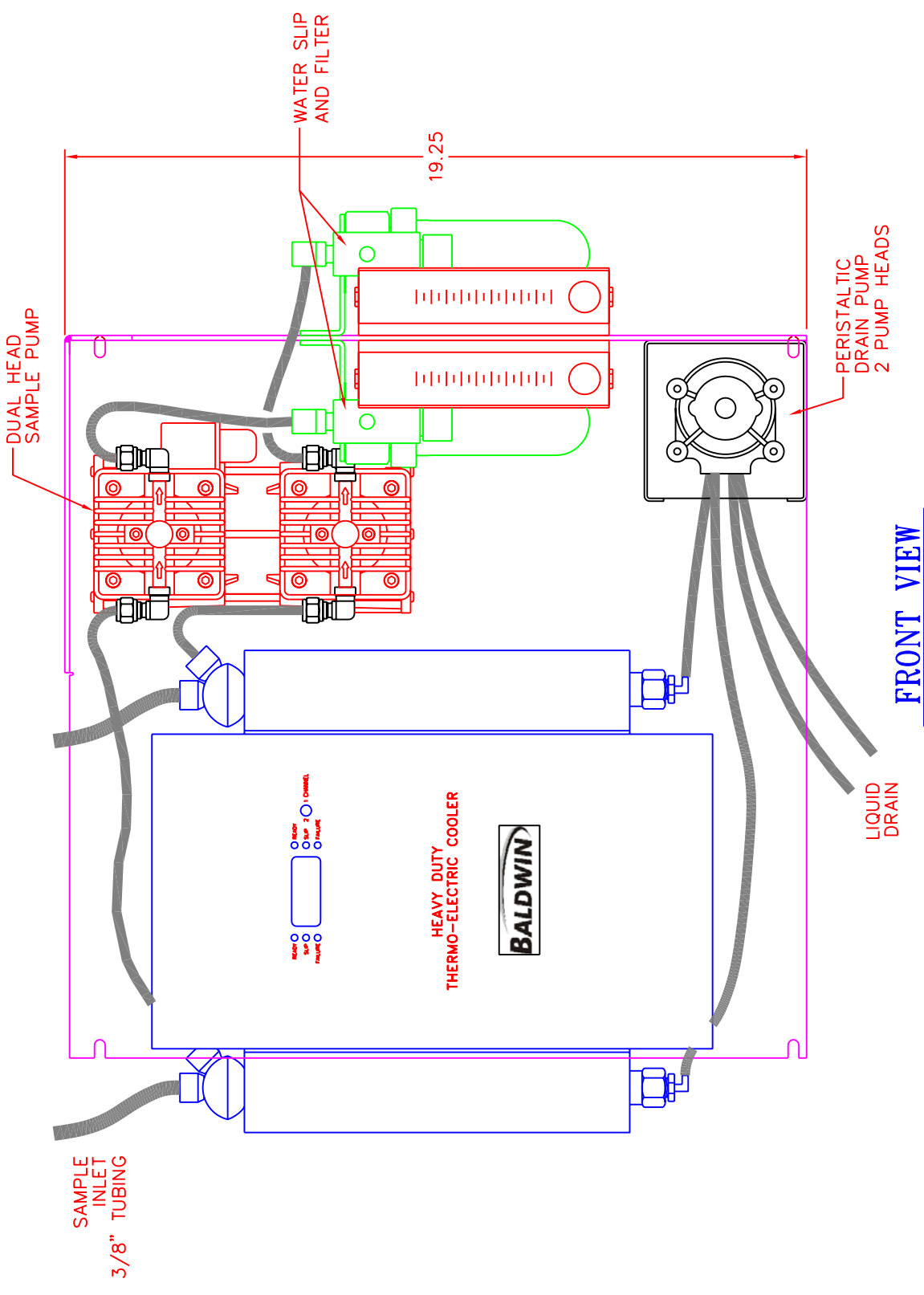

FRONT VIEW

4

5

6

7

8

D C B A

ITEM	QTY	DESCRIPTION	MANUF.
USED FOR: MODEL NUMBER: 12/05/03			
FOR: DESCRIPTION: DATE			
DRAWN BY: DATE			
APP'D: DATE			
MATERIAL			
FINISH			
PART DESCRIPTION: MODEL 4S-8210-9ECD2			
SAMPLE CONDITIONING SYSTEM			
SIZE	SCALE:	DRAWING/PART NO.:	
B	1/4	4S-8210-9ECD2	
DESIGN DIMENSIONS ARE IN INCHES			
() DENOTES MILLIMETER EQUIVALENTS WHEN USED			
CAD DIR: S:\S&M\DWGS\S&M_CON_SYSTEMS\DWG_SHEET_1_OF_1			

PROPRIETARY INFORMATION
THIS DOCUMENT CONTAINS INFORMATION PROPRIETARY TO **BALDWIN, INC.**
AND IS TO BE USED SOLELY FOR THE PURPOSE FOR WHICH IT IS FURNISHED HEREIN. IT IS NOT TO BE USED FOR REVERSE ENGINEERING, REPRODUCTION, OR MANUFACTURING, IN WHOLE OR IN PART.
BALDWIN, INC.

UNLESS OTHERWISE SPECIFIED	1	TOLERANCE DECIMALS	±0.02
	2	PLACE	±0.02
	3	PLACE	±0.010
		ANGLES	±°
		HOLES	+0.003/-0.001
		SPRINGS	TO



1	2	3	4	5	6	7	8
---	---	---	---	---	---	---	---

BRACKET	MODEL C	MODEL C1	MODEL CD	MODEL CD2	MODEL 5
SMALL	M115	M325	M425	M425	
LARGE		5210, 8210	5210, 8210	8210	545, 10410

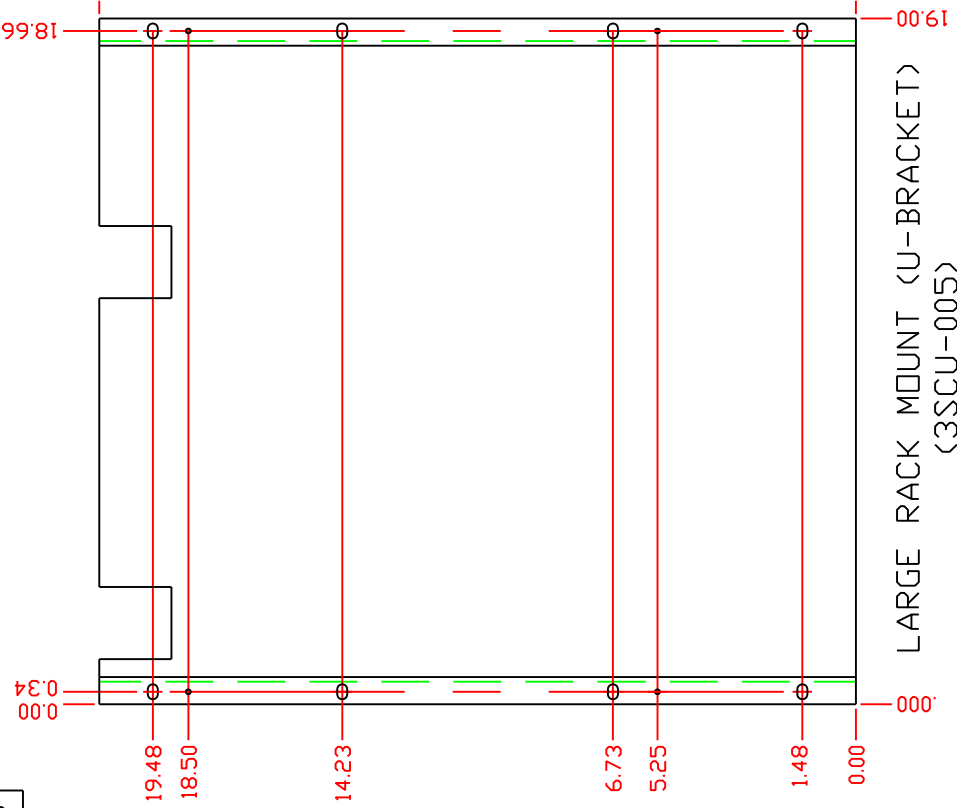
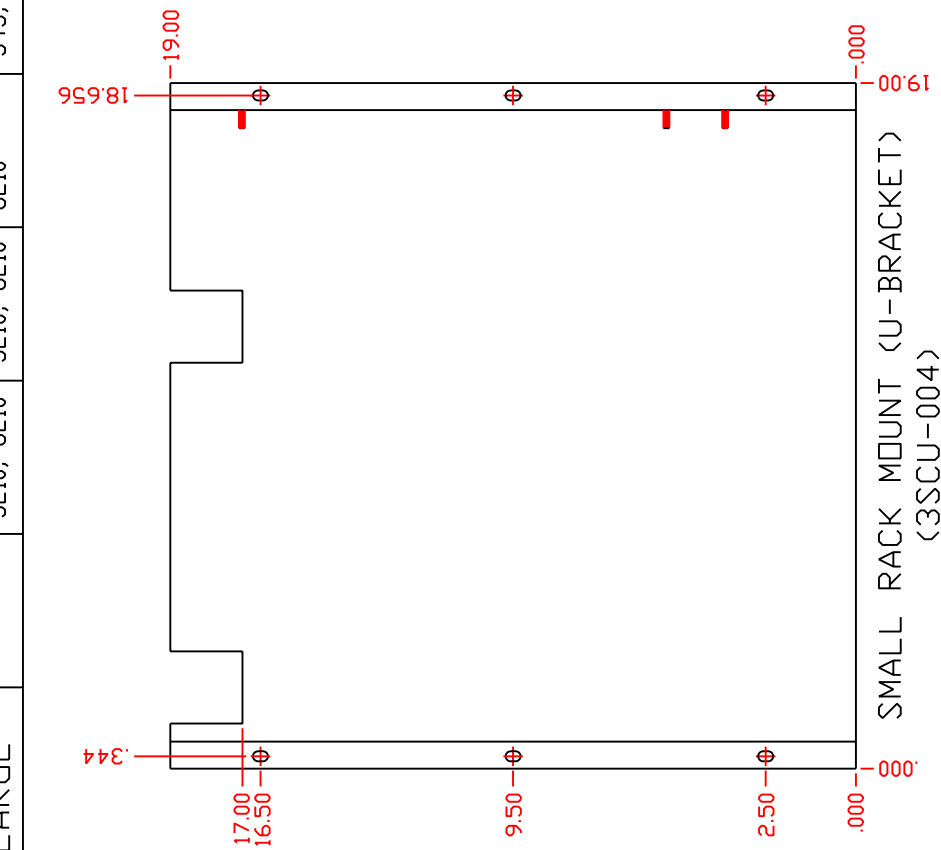

REV/N	DATE	DESCRIPTION	DRAWN	APPROVED
0	00/00/00	INITIAL DRAWING	JD	

ITEM QTY	DESCRIPTION	MANUF.
USED FOR:	MODEL NUMBER:	
DRAWN BY:	DATE:	
APPR:	DATE:	
MATERIAL:	PART DESCRIPTION:	
AS NOTED	SAMPLE CONDITIONER RACK MOUNT MOUNTING DIMENSIONS	
FINISH:	SIZE:	
AS NOTED	A 3/16	
DESIGN DIMENSIONS ARE IN INCHES	DRAWING/PART NO.:	
() DENOTES MILLIMETER EQUIVALENTS WHEN USED	A 3/16 RACK MOUNT	
	CAD DIR: S:\SBA\DWG\S-C-SYSTEMS\WALL MOUNT SHEET 1 DF 1	

PROPRIETARY INFORMATION
THIS DOCUMENT CONTAINS INFORMATION PROPRIETARY TO BALDWIN, INC.
AND IS TO BE USED SOLELY FOR THE PURPOSE FOR WHICH IT IS FURNISHED. THIS DOCUMENT SHALL NOT BE USED FOR ENGINEERING, DESIGN, PROCUREMENT, OR MANUFACTURING, IN WHOLE OR IN PART.
BALDWIN, INC.

UNLESS OTHERWISE SPECIFIED	
TOLERANCE DECIMALS	FINISH
1 PLACE = ±.02	AS NOTED
2 PLACE = ±.02	AS NOTED
3 PLACE = ±.010	
ANGLES = ±5°	
HOLES = +.002/- .001	

BALDWIN
www.baldwinUSA.com

BALDWIN, INC.	
DATE:	06/19/02
DATE:	
MATERIAL:	AS NOTED
FINISH:	AS NOTED
DESIGN DIMENSIONS ARE IN INCHES	
() DENOTES MILLIMETER EQUIVALENTS WHEN USED	
CAD DIR: S:\SBA\DWG\S-C-SYSTEMS\WALL MOUNT SHEET 1 DF 1	

REV/N	DATE	DESCRIPTION	DRAWN	APPROVED
0	00/00/00	INITIAL DRAWING	JD	

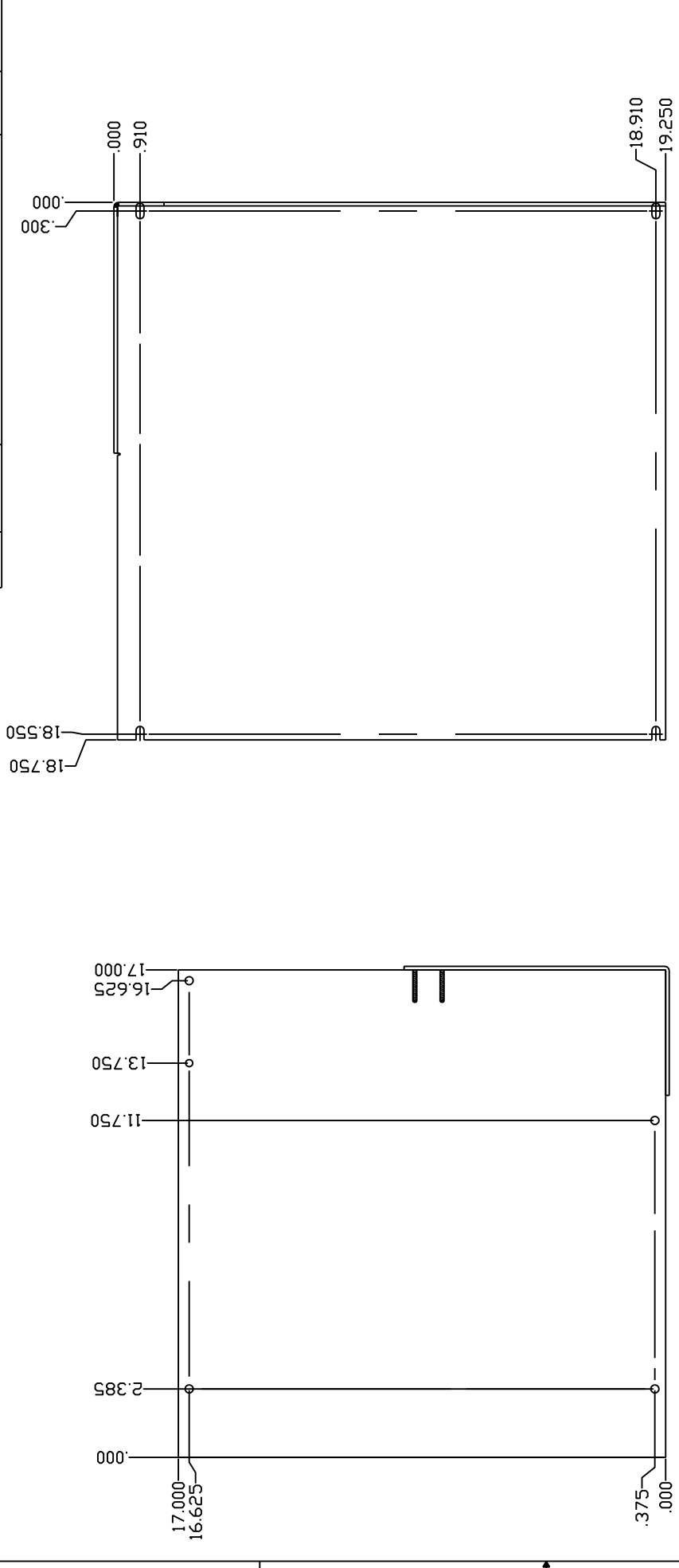

LARGE WALL MOUNT <FLAT PLATE>
(3SCP-001)

BRACKET	MODEL C	MODEL C1	MODEL C2	MODEL CD	MODEL 5
SMALL	M115	M325	M425	M425	
LARGE		5210, 8210	5210, 8210	8210	545, 10410

SMALL WALL MOUNT <FLAT PLATE>
(3SCP-002)

ITEM QTY USED FOR: _____ MODEL NUMBER: _____ DESCRIPTION: _____ MANUF.: _____		DATE JD: 06/19/02 APPR: _____		BALDWIN, INC.	
MATERIAL AS NOTED		PART DESCRIPTION SAMPLE CONDITIONER WALL MOUNT MOUNTING DIMENSIONS		SCALE: A 3/16 WALL MOUNT	
FINISH AS NOTED		DESIGN DIMENSIONS ARE IN INCHES		DRAWING/PART NO.: A 3/16 WALL MOUNT	
PROPRIETARY INFORMATION THIS DOCUMENT CONTAINS INFORMATION PROPRIETARY TO BALDWIN, INC.		AND IS TO BE USED SOLELY FOR THE PURPOSE FOR WHICH IT IS FURNISHED THIS DOCUMENT SHALL NOT BE USED FOR ENGINEERING, DESIGN, PROCUREMENT, OR MANUFACTURING, IN WHOLE OR IN PART.		CAD DIR: S:\SBA\DMG\A-C-SYSTEMS\WALL MOUNT SHEET 1 OF 1	
TOLERANCE UNLESS OTHERWISE SPECIFIED DECIMALS: 1 PLACE = ±.02 2 PLACE = ±.02 3 PLACE = ±.010		ANGLES = ±5° HOLES = +.002/- .001		 www.baldwinUSA.com	



MINI DIA-VAC®

MAINTENANCE AND DISASSEMBLY INSTRUCTIONS

A. General Operations Characteristics

1. Normal motor coil temperatures may be 160 - 180 degrees F. Winding insulation is Class B. Please note the two fans are different, so before removing the fans, note which side they belong on.
2. To check pumping efficiency, employ suitably damped gauges connected so as to dead-end either pressure or vacuum.
NOTE: Check each separately, One or the other port must be open during this test.
Use 0-60 PSI pressure gauge and 0-30 inch hg. vacuum gauge, (or mercury manometer).
Maximum pressure should be at least 33 PSIG for the .160 eccentric.
Maximum vacuum should be 21 inches Hg when using the .160 eccentric.
3. Match electrical power to motor
4. Do not start pump and motor with load of pressure or vacuum on pump head.
5. Pumps are intended for gaseous operation, eliminate liquids entering pump.
6. Nominal running amps for Mini Dia-Vac® at 115/230 volts are 1.7/0.8

B. Maintenance Procedures

1. Motor oiling - No oiling or other lubrication addition is necessary at all. All bearings are pre-lubricated and shielded from external contamination.
2. Diaphragm Replacement (also see Maintenance Procedure Below):
 - a. Standard EPDM (part 4302 or kit 11309) - Operating life can be five years or more under conditions of light pressure or vacuum loads and infrequent operation. Over 20 PSI and constant operation may require 3 month diaphragm inspection procedure. High ambient conditions over 100 degrees F may also decrease diaphragm life.
 - b. Teflon coated EPDM (part 4301 or kit 11305) - Satisfactory operation can be attained for periods of 12 months or more under conditions of light pressure of vacuum loads.
 - c. Viton/Nomex (part 4303 or kit 11307) - same as b above.

Where critical processes may involve the pumping of corrosive or toxic gas media, it is recommended that a monthly check of the diaphragm be part of a scheduled maintenance procedure.

Air Dimensions Inc. will supply recommendations on the choice of diaphragm material and or pump head construction on request.

*Diaphragms require close precision tolerance, therefore only ADI diaphragms should be used as replacements.

C. Disassembly of Head Section and Service Diaphragm

1. Remove head section by unscrewing the four large bolts. A flat-bladed screw driver may be needed to gently pry the head free of the service diaphragm. **If you have Teflon coating on the heads use caution not to scratch the surface.
2. The valve body can then be removed by unscrewing the two smaller screws (also accessible on the top of the head section). This part may be freed by gently tapping on these two screws after they have been loosened about three or four turns. When the valve body is removed, check all internal surfaces for any accumulation of dirt. The two valve discs can be wiped clean and replaced as long as they appear unaffected by usage. The valve gasket can be easily removed and should be inspected. As a matter of good practice, the valve discs and valve gasket should be replaced during any routine maintenance check of the head section. A once a year routine procedure is recommended.
3. The service diaphragm is secured by the single screw in its center. Remove this screw with a 5/32" Allen wrench. The diaphragm and its clamping plate should be easily lifted off. Some slight adherence to the metal may occur if the diaphragm has been in use for a long period.
4. When replacing the service diaphragm, a Teflon washer (part# 23001) should be inserted under the head of the diaphragm cap screw. This is added insurance against small gas leaks through screw heads and may be essential in vacuum applications where outside air contamination cannot be tolerated. After tightening the screw, the excess Teflon should be trimmed away.

NOTE: When replacing the service diaphragm, be sure the four projecting studs of the base casting are properly located in the four outer holes provided in the diaphragm before the part is clamped in place. Be sure the diaphragm plate is firmly replaced with its center screw.

D. Disassembly and Replacement of the Connecting Rod

1. Remove head section and service diaphragm as described in (C) above. When this is done and the front screen has been removed, the connecting rod assembly may be taken out (refer to exploded view drawing). Gently pry up and remove the connecting rod cap (part# 3301) which is held in place by the diaphragm screw.
2. Loosen but do not remove the counterweight screw. This is accessible from the top of the pump base casting and will require a 5/32" hex allen wrench. The connecting rod eccentric assembly, including counterweight and fan, will then slide off the motor shaft.
3. When replacing the eccentric assembly, be careful to align the flat section on the motor shaft with the counterweight screw. The eccentric assembly should be aligned so the fan is on the outer side from the motor. Slide this assembly as far onto the motor shaft as it will go before tightening the counterweight screw onto the flat of the motor.

NOTE: After prolonged use, the eccentric assembly may freeze up on the motor shaft. A wheel puller may be needed to free the part. When replacing the eccentric assembly, the motor shaft should be lightly coated with a graphite or MDS based lubricant.

E. Related Torque Values

1. Head bolts - 110 inch pounds.
2. Valve body screws and Diaphragm plate screws - 70 inch pounds

Dia-Vac® is a Registered Trademark of Air Dimensions Inc.



1. Single Pump Head Loading

Note: Use only MASTERFLEX Precision Tubing with MASTERFLEX Pumps to insure optimum performance. Use of other tubing may void applicable warranties.

Contents: One pump head, one 15 in (38 cm) length of silicone tubing, one mounting hardware package, manual and tubing loading key.

Supplied tubing loading key required for assembly.

- a) Separate the end bells (the pump head halves). Hold the end bell containing the rotor as shown with the tubing retainer grooves facing down.
- b) Place tubing in the right groove and against the first two rollers. Hold tubing with thumb. Near groove, insert smaller prong of loading key between the top of the rotor and tubing. Push key in as far as possible.
- c) Push down and turn key counterclockwise (ccw) completely around the rotor. The key will push the tubing uniformly into the end bell assembly. Hold the second end of tubing. Remove key.
- d) Position the other end bell on top and press the end bells together. Be careful not to pinch the tubing. If end bells do not snap tightly together, reload tubing. If necessary, turn key in slot on rotor shaft to adjust tubing (as in Step e).
- e) With key in slot on rotor shaft, turn key to align tang on rotor shaft with slot in motor drive shaft. Point tubing retainer grooves up. Shift the pump head slightly till it snaps on the alignment pins (if present). Secure with four provided screws. Tighten with fingers only.

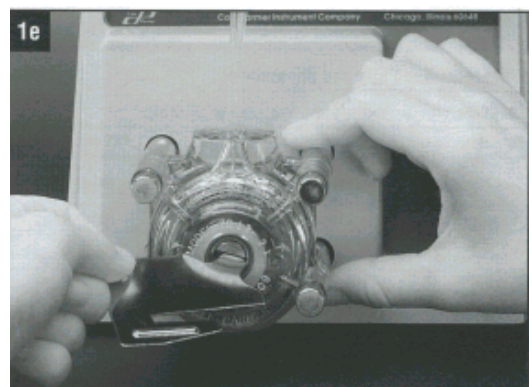
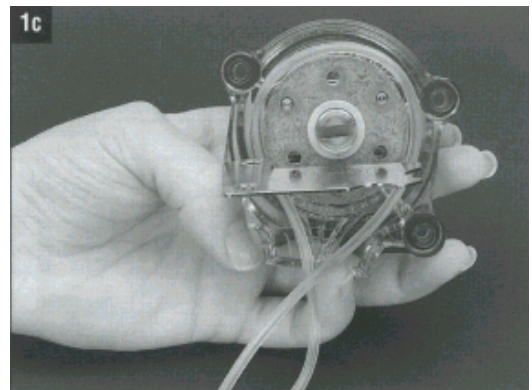
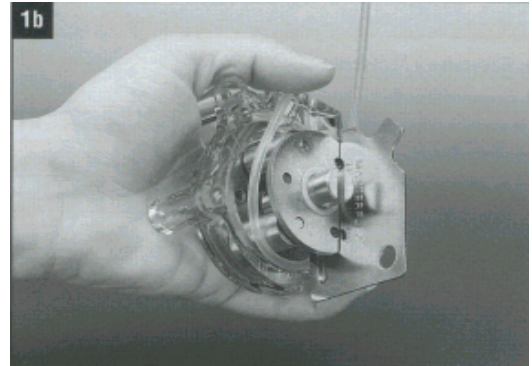
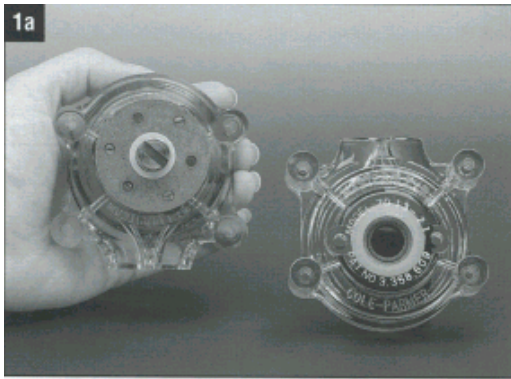

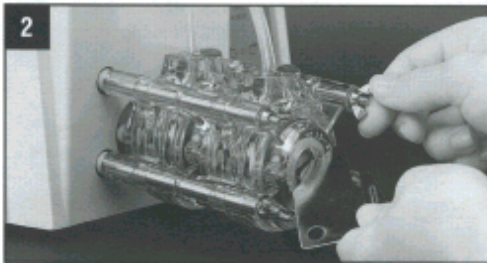

2. Multi-Channel Mounting

Flat bladed screwdriver required for mounting.

Tubing loading key required for mounting.

Note: Other special mounting hardware for multi-channel pumping. See “3. Replacement Parts and Accessories”.

- a) Load the pump heads with tubing.
- b) Install the four correct length-mounting screws in drive.
- c) Slide the first pump head into the mounting screws.
- d) Place key in slot on mounting shaft. Twist to align tang on rotor shaft with slot in motor drive shaft. Shift the pump housing around till it drops over the alignment pins (if present).
- e) Repeat for each additional pump head, aligning pump head tang with slot on previously mounted pump head.
- f) Slide the four flat washers onto screws and secure with the four wingnuts. Tighten with fingers only.
- g) A support bracket is supplied with 3 and 4 channel mounting hardware for additional support. Mount over bottom two screws. Inert one of the three different adjustments screws depending upon drive height.

3. Replacement Parts and Accessories

A. End Bells (order two end bells for a complete head assembly).

Pump Head #	PC Order number	Pump Head #	PC Order number
07013-00, -20	MN-07013-81	-	-
07013-10, -21	MN-07013-91	07013-50, -52	MN-07013-92
07014-00, -20	MN-07014-81	-	-
07014-10, -21	MN-07014-91	07014-50, -52	MN-07014-92
07015-00, -20	MN-07015-81	-	-
07015-10, -21	MN-07015-91	07015-50, -52	MN-07015-92
07016-00, -20	MN-07016-81	-	-
07016-10, -21	MN-07016-91	07016-50, -52	MN-07016-92
07017-00, -20	MN-07017-81	-	-
07017-10, -21	MN-07017-91	07017-50, -52	MN-07017-92
07018-00, -20	MN-07018-81	-	-
07018-10, -21	MN-07018-91	07018-50, -52	MN-07018-92
07024-00, -20	MN-07024-81	-	-
07024-10, -21	MN-07024-91	07024-50, -52	MN-07024-92
07035-02, -20	MN-07035-81	-	-
07035-12, -21	MN-07035-91	-	-

B. Rotor assemblies

Pump Head number	Pump Head suffix	Order number
07013, 07014, 07016 07018	-00	MN-07013-75
	-10, -50	MN-07013-76
	-20	MN-07013-80
	-21, -52	MN-07013-95
07015, 07024, 07035	-00, -02	MN-07013-75
	-10, -50, -12	MN-07013-76
	-20	MN-07013-80
	-21, -52	MN-07013-90

C. MN-07021-04 Thrust washers. Pack of 10.

D. MN-07013-90 Tubing loading key.

E. Mounting hardware for standard pump heads.

Set contains four #8-32 screws, four washers, and four wingnuts.

Number of heads To be mounted	Cold-rolled steel Order number	Stainless steel Order number
1	MN-07013-02	MN-07013-04
2	MN-07013-03	MN-07013-05
3	MN-07013-03	MN-07013-08
4	MN-07013-07	MN-07013-09

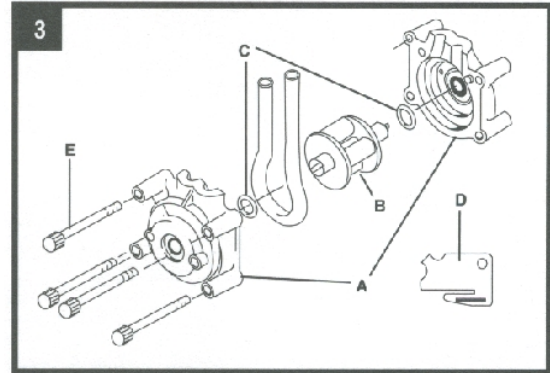

4. Specifications

	Thin wall*	Thick wall*
Maximum continuous discharge pressure-psi(bar):	20(1.4)	25(1.7)
Maximum intermittent discharge pressure-psi(bar):	35(2.4)	40(2.7)
Maximum vacuum:	660(510")m Hg	26(20")in Hg
Maximum suction lift:	8.8(6.7)m H ₂ O	29(22')ft H ₂ O
Number of rollers:	3	
Occlusion:	Standard fixed	
Maximum pump speed (rpm):	600	
Nominal torque load:	6.5 kg-cm(90 oz-in)	
Housing materials:	Polycarbonate (PC) all models, or Polyphenylene sulfide (PPS) all models except 07035	
Roller/rotor materials:	Cold rolled Stl (CRS) or Stainless Stl (SS)	
Operating temperature:	0 to 40° (32 to 104°F)	
*Thin wall: tubing 13, 14, 16, 17, 18	Thick wall: tubing 15, 24, 35	
†With tubing 17 & 18		
‡ Use in this temperature range for continuous duty operation with no decrease in performance or product life. Pump heads will work outside this range with some possible reductions in performance or product life.		

5. Warranty and Return Items

Warranty

Use only MASTERFLEX Precision Tubing with MASTERFLEX Pumps to insure optimum performance. Use of other tubing may void applicable warranties.

The manufacturer warrants this product to be free from any significant deviations from published specifications. If repair or adjustment is necessary within the warranty period, the problem will be corrected at no charge if it is not due to misuse or abuse on your part, as determined by the manufacturer. Repair costs outside the warranty period, or those resulting from product misuse or abuse, may be invoiced to you. The warranty period for this product is noted on the Warranty Card.

Product Return

To limit charges and delays, contact the seller or manufacturer for authorization and shipping instructions before returning the product, either within or outside the warranty period. When returning the product, please state the reason for the return. For your protection, pack the product carefully and insure it against possible damage or loss. Any damages resulting from improper packaging are your responsibility.

Technical Assistance

If you have any questions about the use of this product, contact the manufacturer or authorized dealer.

**CHART OF VOLUME PERCENT WATER CONCENTRATIONS
AT SATURATION FOR VARIOUS TEMPERATURES
AT STANDARD PRESSURE (ATMOSPHERIC PRESSURE)**

DEGREES C	DEGREES F	VOLUME %	DEGREES C	DEGREES F	VOLUME %
+100	+ 212	100.00	+ 2	+ 36	0.696
+ 90	+ 194	69.20	+ 1	+ 34	0.649
+ 80	+ 176	46.70	0	+ 32	0.602
+ 75	+ 167	38.70	- 1	+ 30	0.555
+ 70	+ 158	30.70	- 2	+ 28	0.510
+ 65	+ 149	25.20	- 3	+ 27	0.469
+ 60	+ 140	19.70	- 4	+ 25	0.431
+ 55	+ 131	15.50	- 5	+ 23	0.396
+ 50	+ 122	12.20	- 6	+ 21	0.363
+ 45	+ 113	9.45	- 7	+ 19	0.333
+ 40	+ 104	7.25	- 8	+ 18	0.305
+ 35	+ 95	5.55	- 9	+ 16	0.281
+ 30	+ 86	4.19	- 10	+ 14	0.256
+ 29	+ 84	3.95	- 11	+ 12	0.234
+ 28	+ 82	3.73	- 12	+ 10	0.214
+ 27	+ 81	3.62	- 13	+ 9	0.196
+ 26	+ 79	3.32	- 14	+ 7	0.179
+ 25	+ 77	3.13	- 15	+ 5	0.163
+ 24	+ 75	2.94	- 16	+ 3	0.148
+ 23	+ 73	2.77	- 17	+ 1	0.135
+ 22	+ 72	2.61	- 18	0	0.123
+ 21	+ 70	2.46	- 19	- 2	0.112
+ 20	+ 68	3.31	- 20	- 4	0.102
+ 19	+ 66	2.17	- 22	- 8	0.084
+ 18	+ 64	2.04	- 24	- 11	0.069
+ 17	+ 63	1.91	- 26	- 15	0.057
+ 16	+ 61	1.79	- 28	- 18	0.046
+ 15	+ 59	1.68	- 30	- 22	0.038
+ 14	+ 57	1.58	- 32	- 26	0.031
+ 13	+ 55	1.48	- 34	- 30	0.025
+ 12	+ 54	1.38	- 36	- 34	0.019
+ 11	+ 52	1.29	- 38	- 37	0.016
+ 10	+ 50	1.21	- 40	- 40	0.013
+ 9	+ 48	1.13	- 42	- 44	0.011
+ 8	+ 46	1.06	- 44	- 47	0.008
+ 7	+ 45	0.988	- 46	- 51	0.006
+ 6	+ 43	0.922	- 48	- 54	0.005
+ 5	+ 41	0.861	- 50	- 58	0.004
+ 4	+ 39	0.803	- 52	- 62	0.003
+ 3	+ 37	0.751	- 54	- 65	0.002

MOISTURE CONVERSION TABLE

DEWPOINT		VAPOR PRESSURE (WATER/ICE in EQUILIBRIUM) mm MERCURY	PPM on VOLUME BASIS at 760 mm of Hg PRESSURE	RELATIVE HUMIDITY at 70 F	PPM on WEIGHT BASIS in AIR
F	C				
-110	-166	.000010	.00132	.0000053	.00082
-108	-162	.000018	.00237	.0000096	.0015
-106	-159	.000028	.00368	.000015	.0023
-104	-155	.000043	.00566	.000023	.0035
-102	-152	.000065	.00855	.000035	.0053
-100	-148	.000099	.0130	.000053	.0081
-98	-144	.00015	.0197	.000080	.012
-96	-141	.00022	.0289	.00012	.018
-94	-137	.00033	.0434	.00018	.027
-92	-134	.00048	.0632	.00026	.039
-90	-130	.0007	.0921	.00037	.057
-88	-126	.0010	.132	.00054	.082
-86	-123	.0014	.184	.00075	.11
-84	-119	.0020	.263	.00107	.16
-82	-116	.0029	.382	.00155	.24
-80	-112	.0040	.562	.00214	.33
-78	-108	.0056	.737	.00300	.46
-76	-105	.0077	1.01	.00410	.63
-74	-101	.0105	1.38	.00559	.86
-72	-98	.0143	1.88	.00762	1.17
-70	-94	.0194	2.55	.0104	1.58
-68	-90	.0261	3.43	.0140	2.13
-66	-87	.0349	4.59	.0187	2.84
-64	-83	.0464	6.11	.0248	3.79
-62	-80	.0614	8.08	.0328	5.01
-60	-76	.0808	10.6	.0430	6.59
-58	-72	.106	13.9	.0565	8.63
-56	-69	.138	18.2	.0735	11.3
-54	-65	.178	23.4	.0948	14.5
-52	-62	.230	30.3	.123	18.8
-50	-58	.295	38.8	.157	24.1
-48	-54	.378	49.7	.202	30.9
-46	-51	.481	63.3	.257	39.3
-44	-47	.609	80.0	.325	49.7
-42	-44	.768	101	.410	62.7
-40	-40	.966	127	.516	78.9
-38	-36	1.209	159	.644	98.6
-36	-33	1.507	198	.804	122.9
-34	-29	1.873	246	1.00	152
-32	-26	2.318	305	1.24	189
-30	-22	2.859	376	1.52	234
-28	-18	3.51	462	1.88	287
-26	-15	4.30	566	2.30	351
-24	-11	5.26	692	2.81	430
-22	-8	6.40	842	3.41	523
-20	-4	7.76	1020	4.13	633
-18	0	9.39	1240	5.00	770
-16	+3	1.132	1490	6.03	925
-14	+7	1.361	1790	7.25	1110
-12	+10	1.632	2150	8.69	1335
-10	+14	1.950	2570	10.4	1596
-8	+18	2.326	3060	12.4	1900
-6	+21	2.765	3640	14.7	2260
-4	+25	3.280	4230	17.5	2680
-2	+28	3.880	5100	20.7	3170
0	+32	4.579	6020	24.4	3640
+2	+36	5.294	6970	28.2	4330
+4	+39	6.101	8030	32.5	4990
+6	+43	7.013	9230	37.4	5730
+8	+46	8.045	10590	42.9	6580
+10	+50	9.029	12120	49.1	7530
+12	+54	10.52	13840	56.1	8600
+14	+57	11.99	15780	63.9	9800
+16	+61	13.63	17930	72.6	11140
+18	+64	15.48	20370	82.5	12650
+20	+68	17.54	23080	93.5	14330
+22	+71	19.827	26088		16699
+24	+75	33.377	29443		18847
+26	+79	25.209	33169		21232
+28	+8				